

# DEVELON

## Wheel Excavator

# DX190W-7



### Engine

Make	DEVELON
Model	DL06V
Number of cylinders	6
Rated power, gross (hp per SAE J1995)	174.3 hp (130 kW) @ 1900 rpm
Rated power, net (hp per SAE J1349)	159.6 hp (119 kW) @ 1900 rpm
Max. torque, net (SAE J1995)	557 lbf.ft. (755 Nm) @ 1400 rpm
Displacement	359 in. <sup>3</sup> (5.9 L)
Bore and stroke	3.9 in. x 4.9 in. (100 mm x 125 mm)
Starter	24 V, 8.6 hp (6.0 kW)
Battery (qty 2)	12 V, 150 AH
Alternator	24 V, 100 amp
Air cleaner	Three-stage

### Hydraulics

Main pumps	2 x 44.4 gpm (2 x 168 L/min.)
Pilot pump (gear design)	6.9 gpm (26.1 L/min.)

### Working Pressure

Boom/arm/bucket (normal mode)	4975 psi (350 kg/cm <sup>2</sup> )
Boom/arm/bucket (power boost)	5265 psi (370 kg/cm <sup>2</sup> )
Travel	5134 psi (361 kg/cm <sup>2</sup> )
Swing	3916 psi (275 kg/cm <sup>2</sup> )
Pilot	580 psi (41 kg/cm <sup>2</sup> )

### Tires & Wheels (standard)

Type	Double
Tire specification	10.0 - 20 - 16 PR, OTR, TUBE
Rim specification	7.50 T x 20
Disc offset	155 mm

### Swing Mechanism

Swing speed	0 - 11.2 rpm
Swing torque	36382 lbf.ft. (5030 kgf.m)

### Drive System

Travel speed (creep - low - high)	2.17 - 5.6 - 21.75 mph (3.5 - 9.0 - 35 km/h)
Traction force, max. (drawbar pull)	23600 lbf.ft. (10704 kgf.m)
Max. grade (limited by engine lubrication)	58% (29°)

### Environment

Sound level (2000/14/EC)	99 dB(A)
Cabin sound level (ISO 6396)	70 dB(A)

### Refill Capacities

Fuel tank	79.52 gal. (301 L)
DEF tank	8.3 gal. (31.5 L)
Cooling system (radiator capacity)	8.56 gal. (32.4 L)
Engine oil	7.13 gal. (27 L)
Swing drive	1.3 gal. (5 L)
Front axle	2.4 gal. (9.0 L)
Front hub (2x)	0.63 gal. (2.4 L)
Rear axle	3.1 gal. (11.6 L)
Rear hub (2x)	0.63 gal. (2.4 L)
Transmission	0.66 gal. (2.5 L)
Hydraulic system	54.16 gal. (205 L)
Hydraulic tank	50.72 gal. (192 L)

# Technical Specifications

## Hydraulic Cylinders

	Mono Boom (US20/30)	Articulated Boom (US40/50)
Boom main (2) bore x rod diameter x stroke	4.7 in. x 3.3 in. x 46.5 in. (120 mm x 85 mm x 1180 mm)	4.7 in. x 3.3 in. x 40.0 in. (120 mm x 85 mm x 1015 mm)
Boom articulated (1) bore x rod diameter x stroke	–	6.3 in. x 3.7 in. x 29.9 in. (160 mm x 95 mm x 760 mm)
Arm* (1) bore x rod diameter x stroke	4.9 in. x 3.5 in. x 57.9 in. (125 mm x 90 mm x 1470 mm)	
Bucket (STD) (1) bore x rod diameter x stroke	4.3 in. x 30.0 in. x 40.6 in. (110 mm x 75 mm x 1030 mm)	
Steering (1) bore x rod diameter x stroke	5.3 in. x 3.9 in. x 56.8 in. (135 mm x 100 mm x 1443 mm)	
Chocking (2) bore x rod diameter x stroke	3.9 in. x 3.9 in. x 6.0 in. (100 mm x 100 mm x 153 mm)	
Stabilizer (2) bore x rod diameter x stroke	4.3 in. x 2.8 in. x 17.2 in. (110 mm x 70 mm x 438 mm)	
Dozer (2) bore x rod diameter x stroke	4.3 in. x 2.8 in. x 6.7 in. (110 mm x 70 mm x 170 mm)	
Outrigger (2 or 4) bore x rod diameter x stroke	5.1 in. x 3.1 in. x 15.6 in. (130 mm x 80 mm x 397 mm)	

\*Does not include cushioning

The piston rods and cylinder bodies are made of high-strength steel. A shock-absorbing mechanism is fitted in all cylinders to ensure shock-free operation and extended piston life.

# Dimensions

	Mono Boom Dozer/Outriggers (2 R) (US20)		Articulated Boom Dozer/Outriggers (2 R) (US40)	
		Outriggers (2 F/2 R) (US30)		Outriggers (2 F/2 R) (US50)
Boom length	17' 0" (5200 mm)		17' 10" (5440 mm) Lower: 6' 4" (1940 mm) Upper: 12' 6" (3820 mm)	
Arm length	8' 6" (2600 mm)		7' 7" (2300 mm)	
Bucket type (SAE) (PCSA)	1.05 yd <sup>3</sup> (0.80 m <sup>3</sup> )		0.99 yd <sup>3</sup> (0.76 m <sup>3</sup> )	
Shipping length	A	29' 1" (8865 mm)		30' 5" (9260 mm)
Shipping width	B	8' 3" (2530 mm)		
Shipping height (boom)	C	9' 4" (2850 mm)		8' 11" (2720 mm)
Shipping height (hose)		29' 1" (8865 mm)		
Overall height – cab	D	10' 3" (3131 mm)		
Overall height to guardrail		10' 11" (3321 mm)		
Cabin height above house		1' 8" (519 mm)		
Tail swing radius	E	8' 7" (2612 mm)		
Ground clearance	F	1' 2" (347 mm)		
Counterweight clearance	G	4' 0" (1244 mm)		
Engine cover height	H	7' 6" (2291 mm)		
Upper housing width	I	8' 4" (2530 mm)		
Wheel base	J	8' 8" (2650 mm)		
Tread width	K	6' 5" (1944 mm)		
Tread width wide angle		6' 11" (2114 mm)		
Blade width*	8' 4" (2530 mm)	-	8' 4" (2530 mm)	-
Overall undercarriage length*	16' 3" (4957 mm)	16' 5" (4996 mm)	16' 3" (4957 mm)	16' 5" (4996 mm)
Outrigger length (rear)*	3' 5" (2530 mm)			
Outrigger length (front)*	-	3' 7" (1086 mm)	-	3' 7" (1086 mm)
Blade length (front)*	3' 9" (1143 mm)	-	3' 9" (1143 mm)	-
Blade clearance (raised)*	1' 6" (448 mm)	-	1' 6" (448 mm)	-
Blade height*	2' 1" (628 mm)	-	2' 1" (628 mm)	-
Max. blade depth*	5.3" (135 mm)	-	5.3" (135 mm)	-
Outrigger width (ground)*	12' 1" (3696 mm)			
Outrigger width (max. depth)*	11' 9" (3569 mm)			
Max. outrigger depth*	3.5" (90 mm)			
Tire size	10.0 – 20 – 16 PR			

\*Not shown on diagram

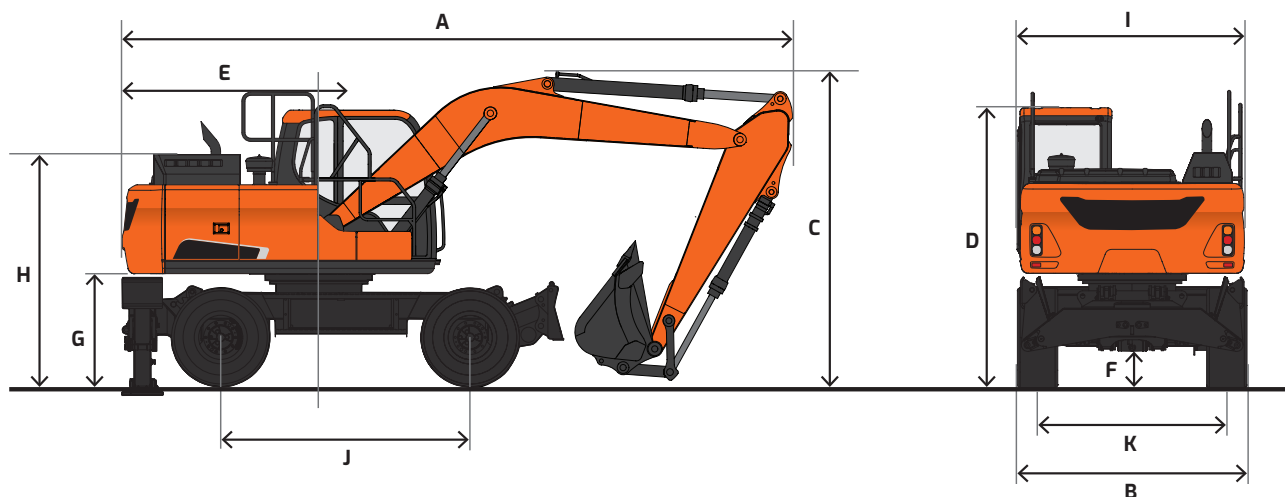

# Working Range

	Mono Boom Dozer/Outriggers (2 R) (US20)		Outriggers (2 F/2 R) (US30)	Articulated Boom Dozer/Outriggers (2 R) (US40)		Outriggers(2 F/2 R) (US50)
	Boom length	17' 1" (5200 mm)			17' 10" (5440 mm) Lower: 6' 4" (1940 mm) Upper: 12' 6" (3820 mm)	
Arm length	8' 6" (2600 mm)			7' 7" (2300 mm)		
Bucket type (SAE, PCSA)	1.05 yd <sup>3</sup> (0.80 m <sup>3</sup> )			0.99 yd <sup>3</sup> (0.76 m <sup>3</sup> )		
Max. digging reach	A	30' 4" (9255 mm)		31' 0" (9255 mm)		
Max. digging reach (ground)	B	29' 8" (9050 mm)		30' 4" (9255 mm)		
Max. digging depth	C	18' 9" (5725 mm)		18' 5" (5610 mm)		
Max. loading height	D	22' 2" (6765 mm)		25' 7" (7805 mm)		
Min. loading height	E	4' 6" (1372 mm)		7' 11" (2438 mm)		
Max. digging height	F	31' 0" (9440 mm)		34' 10" (10625 mm)		
Max. bucket pin height	G	26' 10" (8180 mm)		30' 3" (9210 mm)		
Max. vertical wall depth	H	15' 7" (4740 mm)		15' 2" (4630 mm)		
Max. radius vertical	I	20' 9" (6330 mm)		18' 8" (5680 mm)		
Max. depth to 8' line	J	18' 2" (5530 mm)		18' 1" (5505 mm)		
Min. radius to 8' line	K	9' 0" (2755 mm)		3' 1" (930 mm)		
Min. digging reach	L	15" (390 mm)		-		
Min. swing radius	M	10' 5" (3170 mm)		9' 10" (2995 mm)		
Digging force, bucket*	SAE	26527 lbf. (12032 kgf)				
Digging force, arm*		20952 lbf. (9503 kgf)		22487 lbf. (10200 kgf)		
Operating weight		46187 lb. (20950 kg)	47104 lb. (21366 kg)	46263 lb. (20985 kg)	47180 lb. (21401 kg)	

\*With power boost ON

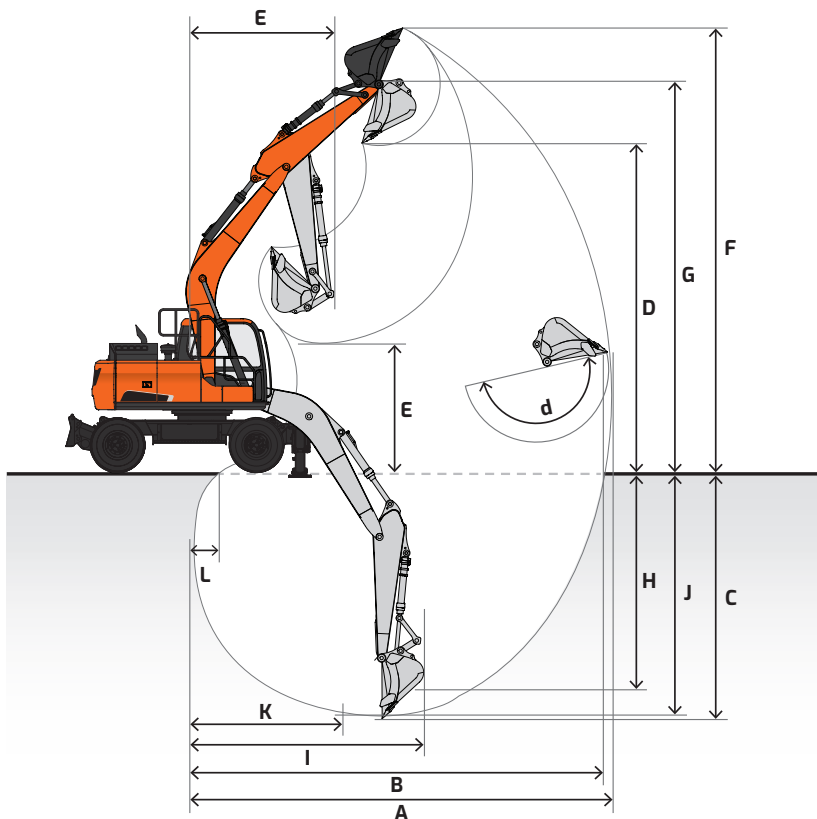















# Lifting Capacity

 Rating over front     Rating over side or 360°















## DX190W-7 US20

Mono Boom: 17' 1" (5200 mm) | Arm: 8' 6" (2600 mm) | Counterweight: 7084 lb. (3220 kg) | Front Dozer & Rear Outriggers UP | Bucket: None | Unit: lb. (kg)

B (ft. or m)	A (ft. or m)		5' (1.5 m)		10' (3.0 m)		15' (4.5 m)		20' (6.0 m)		25' (7.5 m)		Max. Reach	
														
25' (7.5 m)												* 7780 (* 3530)	* 7780 (* 3530)	1724' (5.25 m)
20' (6.0 m)								* 10630 (* 4820)	7400 (3360)			* 6860 (* 3110)	6450 (2930)	216' (6.58 m)
15' (4.5 m)					* 14650 (* 6650)	11250 (5100)	11050 (5010)	7230 (3280)				* 6590 (* 2990)	5280 (2400)	2414' (736 m)
10' (3.0 m)					16570 (7520)	10410 (4720)	10660 (4840)	6880 (3120)	7570 (3430)	4870 (2210)		* 6680 (* 3030)	4730 (2150)	2544' (775 m)
5' (1.5 m)					15660 (7110)	9620 (4360)	10260 (4650)	6520 (2960)	7410 (3360)	4730 (2150)		* 7100 (* 3220)	4540 (2060)	25.69' (783 m)
Ground Level			* 16100 (* 7300)	* 16100 (* 7300)	15170 (6880)	9190 (4170)	9980 (4530)	6260 (2840)				7340 (3330)	4660 (2110)	24.93' (760 m)
-5' (-1.5 m)	* 16650 (* 7550)	* 16650 (* 7550)	* 27100 (* 12290)	16440 (7460)	15060 (6830)	9090 (4120)	9900 (4490)	6190 (2810)				8190 (3710)	5180 (2350)	23.04' (702 m)
-10' (-3.0 m)			* 26720 (* 12120)	16830 (7640)	15260 (6920)	9270 (4210)						10350 (4690)	6530 (2960)	19.69' (6.00 m)

## DX190W-7 US20

Mono Boom: 17' 1" (5200 mm) | Arm: 8' 6" (2600 mm) | Counterweight: 7084 lb. (3220 kg) | Front Dozer & Rear Outriggers DOWN | Bucket: None | Unit: lb. (kg)

B (ft. or m)	A (ft. or m)		5' (1.5 m)		10' (3.0 m)		15' (4.5 m)		20' (6.0 m)		25' (7.5 m)		Max. Reach		
															
25' (7.5 m)													* 7780 (* 3530)	* 7780 (* 3530)	1724' (5.25 m)
20' (6.0 m)								* 10630 (* 4820)	* 10630 (* 4820)				* 6860 (* 3110)	* 6860 (* 3110)	216' (6.58 m)
15' (4.5 m)					* 14650 (* 6650)	* 14650 (* 6650)	* 12950 (* 5870)	11590 (5260)					* 6590 (* 2990)	* 6590 (* 2990)	2414' (736 m)
10' (3.0 m)					* 18230 (* 8270)	17440 (7910)	* 14420 (* 6540)	11200 (5080)	* 8760 (* 3980)	7950 (3610)		* 6680 (* 3030)	* 6680 (* 3030)	2544' (775 m)	
5' (1.5 m)					* 21530 (* 9760)	16520 (7490)	* 15940 (* 7230)	10790 (4900)	* 10730 (* 4870)	7800 (3540)		* 7100 (* 3220)	* 7100 (* 3220)	25.69' (783 m)	
Ground Level			* 16100 (* 7300)	* 16100 (* 7300)	* 22950 (* 10410)	16020 (7270)	* 16770 (* 7610)	10510 (4770)				* 7960 (* 3610)	7730 (3510)	24.93' (760 m)	
-5' (-1.5 m)	* 16650 (* 7550)	* 16650 (* 7550)	* 27100 (* 12290)	* 27100 (* 12290)	* 22230 (* 10080)	15900 (7210)	* 16260 (* 7370)	10430 (4730)				* 9640 (* 4370)	8620 (3910)	23.04' (702 m)	
-10' (-3.0 m)			* 26720 (* 12120)	* 26720 (* 12120)	* 19010 (* 8620)	16120 (7310)						* 13090 (* 5940)	10890 (4940)	19.69' (6.00 m)	

A Distance from center of rotation  
B Height

NOTE: Lifting capacities are in compliance with SAE 1097 and ISO 10567. Machine in lifting mode with power boost turned on. Load point is the end of the arm. Rated loads shown do not exceed 75% of minimum tipping loads or 87% of hydraulic capacities. Rated loads marked with an asterisk (\*) are limited by hydraulic capacities. The least stable position is over the side. The total mass of machine includes the mass of the boom, arm, counterweight, all operating fluids and 165 lb. (75 kg) operator.

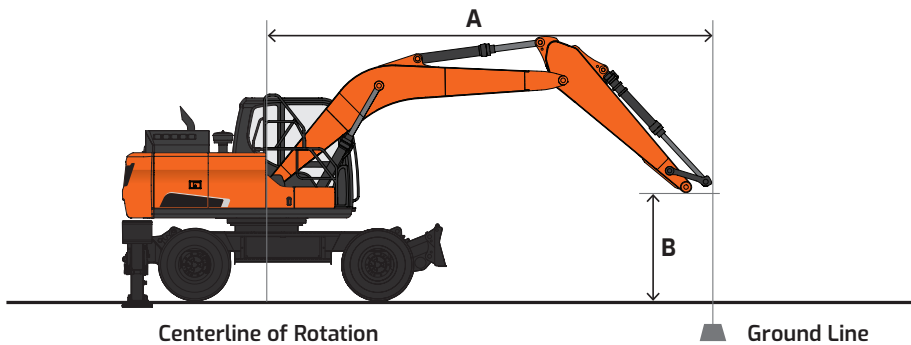













# Lifting Capacity

 Rating over front     Rating over side or 360°













## DX190W-7 US30

Mono Boom: 17' 1" (5200 mm) | Arm: 8' 6" (2600 mm) | Counterweight: 7084 lb. (3220 kg) | Front & Rear Outriggers UP | Bucket: None | Unit: lb. (kg)

B (ft. or m) A (ft. or m)	5' (1.5 m)		10' (3.0 m)		15' (4.5 m)		20' (6.0 m)		25' (7.5 m)		Max. Reach		
													A
25' (7.5 m)											* 7780 (* 3530)	* 7780 (* 3530)	1724' (5.25 m)
20' (6.0 m)							* 10630 (* 4820)	7440 (3370)			* 6860 (* 3110)	6480 (2940)	216' (6.58 m)
15' (4.5 m)					* 14650 (* 6650)	11300 (5130)	11010 (4990)	7270 (3300)			* 6590 (* 2990)	5310 (2410)	2414' (7.36 m)
10' (3.0 m)					16510 (7490)	10460 (4740)	10620 (4820)	6920 (3140)	7530 (3420)	4900 (2220)	* 6680 (* 3030)	4760 (2160)	2544' (7.75 m)
5' (1.5 m)					15600 (7080)	9670 (4390)	10220 (4640)	6550 (2970)	7380 (3350)	4760 (2160)	7090 (3210)	4570 (2070)	2569' (7.83 m)
Ground Level			* 16100 (* 7300)	* 16100 (* 7300)	15110 (6850)	9240 (4190)	9940 (4510)	6300 (2860)			7310 (3320)	4690 (2130)	2493' (7.60 m)
-5' (-1.5 m)	* 16650 (* 7550)	* 16650 (* 7550)	* 27100 (* 12290)	16530 (7500)	14990 (6800)	9140 (4150)	9860 (4470)	6230 (2820)			8150 (3700)	5210 (2360)	2304' (7.02 m)
-10' (-3.0 m)			* 26720 (* 12120)	16920 (7680)	15200 (6900)	9320 (4230)					10310 (4680)	6560 (2980)	1969' (6.00 m)

## DX190W-7 US30

Mono Boom: 17' 1" (5200 mm) | Arm: 8' 6" (2600 mm) | Counterweight: 7084 lb. (3220 kg) | Front & Rear Outriggers DOWN | Bucket: None | Unit: lb. (kg)

B (ft. or m) A (ft. or m)	5' (1.5 m)		10' (3.0 m)		15' (4.5 m)		20' (6.0 m)		25' (7.5 m)		Max. Reach		
													A
25' (7.5 m)											* 7780 (* 3530)	* 7780 (* 3530)	1724' (5.25 m)
20' (6.0 m)							* 10630 (* 4820)	* 10630 (* 4820)			* 6860 (* 3110)	* 6860 (* 3110)	216' (6.58 m)
15' (4.5 m)					* 14650 (* 6650)	* 14650 (* 6650)	* 12950 (* 5870)	* 12950 (* 5870)			* 6590 (* 2990)	* 6590 (* 2990)	2414' (7.36 m)
10' (3.0 m)					* 18230 (* 8270)	* 18230 (* 8270)	* 14420 (* 6540)	13580 (6160)	* 8760 (* 3980)	* 8760 (* 3980)	* 6680 (* 3030)	* 6680 (* 3030)	2544' (7.75 m)
5' (1.5 m)					* 21530 (* 9760)	20610 (9350)	* 15940 (* 7230)	13150 (5960)	* 10730 (* 4870)	9420 (4280)	* 7100 (* 3220)	* 7100 (* 3220)	2569' (7.83 m)
Ground Level			* 16100 (* 7300)	* 16100 (* 7300)	* 22950 (* 10410)	20060 (9100)	* 16770 (* 7610)	12850 (5830)			* 7960 (* 3610)	* 7960 (* 3610)	2493' (7.60 m)
-5' (-1.5 m)	* 16650 (* 7550)	* 16650 (* 7550)	* 27100 (* 12290)	* 27100 (* 12290)	* 22230 (* 10080)	19940 (9040)	* 16260 (* 7370)	12770 (5790)			* 9640 (* 4370)	* 9640 (* 4370)	2304' (7.02 m)
-10' (-3.0 m)			* 26720 (* 12120)	* 26720 (* 12120)	* 19010 (* 8620)	* 19010 (* 8620)					* 13090 (* 5940)	* 13090 (* 5940)	1969' (6.00 m)

A Distance from center of rotation

B Height

NOTE: Lifting capacities are in compliance with SAE 1097 and ISO 10567. Machine in lifting mode with power boost turned on. Load point is the end of the arm. Rated loads shown do not exceed 75% of minimum tipping loads or 87% of hydraulic capacities. Rated loads marked with an asterisk (\*) are limited by hydraulic capacities. The least stable position is over the side. The total mass of machine includes the mass of the boom, arm, counterweight, all operating fluids and 165 lb. (75 kg) operator.

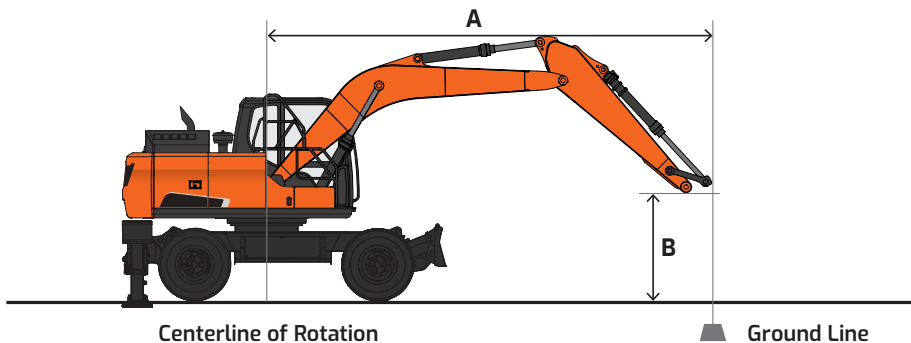













# Lifting Capacity

 Rating over front     Rating over side or 360°













## DX190W-7 US40

2-PC Boom: 18' 0" (5400 mm) | Arm: 7' 7" (2300 mm) | Counterweight: 7084 lb. (3220 kg) | Front Dozer & Rear Outriggers UP | Bucket: None | Unit: lb. (kg)

A (ft. or m) B (ft. or m)	5' (1.5 m)		10' (3.0 m)		15' (4.5 m)		20' (6.0 m)		25' (7.5 m)		Max. Reach		
													A
30' (9.0 m)											* 12080 (* 5480)	* 12080 (* 5480)	10.25' (3.12 m)
25' (7.5 m)					* 12400 (* 5630)	11580 (5250)					* 7580 (* 3440)	* 7580 (* 3440)	18.19' (5.55 m)
20' (6.0 m)					* 12600 (* 5720)	11450 (5200)	11080 (5030)	7210 (3270)			* 6380 (* 2890)	5860 (2660)	22.35' (6.81 m)
15' (4.5 m)					* 14950 (* 6780)	10800 (4900)	10840 (4920)	6990 (3170)			* 5890 (* 2670)	4860 (2200)	24.81' (7.56 m)
10' (3.0 m)					16050 (7280)	9880 (4480)	10430 (4730)	6620 (3000)	7450 (3380)	4720 (2140)	* 5750 (* 2610)	4390 (1990)	26.08' (7.95 m)
5' (1.5 m)					15220 (6900)	9160 (4150)	10040 (4550)	6260 (2840)	7300 (3310)	4590 (2080)	* 5880 (* 2670)	4250 (1930)	26.33' (8.03 m)
Ground Level					14900 (6760)	8880 (4030)	9820 (4450)	6060 (2750)	7230 (3280)	4520 (2050)	* 6290 (* 2850)	4400 (2000)	25.59' (7.80 m)
-5' (-1.5 m)					14930 (6770)	8910 (4040)	9810 (4450)	6050 (2750)			* 7450 (* 3380)	4930 (2240)	23.74' (7.24 m)

## DX190W-7 US40

2-PC Boom: 18' 0" (5400 mm) | Arm: 7' 7" (2300 mm) | Counterweight: 7084 lb. (3220 kg) | Front Dozer & Rear Outriggers DOWN | Bucket: None | Unit: lb. (kg)

A (ft. or m) B (ft. or m)	5' (1.5 m)		10' (3.0 m)		15' (4.5 m)		20' (6.0 m)		25' (7.5 m)		Max. Reach		
													A
30' (9.0 m)											* 12080 (* 5480)	* 12080 (* 5480)	10.25' (3.12 m)
25' (7.5 m)					* 12400 (* 5630)	* 12400 (* 5630)					* 7580 (* 3440)	* 7580 (* 3440)	18.19' (5.55 m)
20' (6.0 m)					* 12600 (* 5720)	* 12600 (* 5720)	* 11920 (* 5400)	11620 (5270)			* 6380 (* 2890)	* 6380 (* 2890)	22.35' (6.81 m)
15' (4.5 m)					* 14950 (* 6780)	* 14950 (* 6780)	* 12650 (* 5740)	11380 (5160)			* 5890 (* 2670)	* 5890 (* 2670)	24.81' (7.56 m)
10' (3.0 m)					* 18510 (* 8400)	16920 (7670)	* 14130 (* 6410)	10970 (4970)	* 12230 (* 5550)	7830 (3550)	* 5750 (* 2610)	* 5750 (* 2610)	26.08' (7.95 m)
5' (1.5 m)					* 21490 (* 9750)	16080 (7290)	* 15620 (* 7080)	10570 (4800)	* 12780 (* 5800)	7680 (3490)	* 5880 (* 2670)	* 5880 (* 2670)	26.33' (8.03 m)
Ground Level					* 22580 (* 10240)	15750 (7150)	* 16460 (* 7460)	10350 (4690)	* 12650 (* 5740)	7620 (3450)	* 6290 (* 2850)	* 6290 (* 2850)	25.59' (7.80 m)
-5' (-1.5 m)					* 21840 (* 9910)	15790 (7160)	* 16120 (* 7310)	10340 (4690)			* 7450 (* 3380)	* 7450 (* 3380)	23.74' (7.24 m)

A Distance from center of rotation  
B Height

NOTE: Lifting capacities are in compliance with SAE 1097 and ISO 10567. Machine in lifting mode with power boost turned on. Load point is the end of the arm. Rated loads shown do not exceed 75% of minimum tipping loads or 87% of hydraulic capacities. Rated loads marked with an asterisk (\*) are limited by hydraulic capacities. The least stable position is over the side. The total mass of machine includes the mass of the boom, arm, counterweight, all operating fluids and 165 lb. (75 kg) operator.

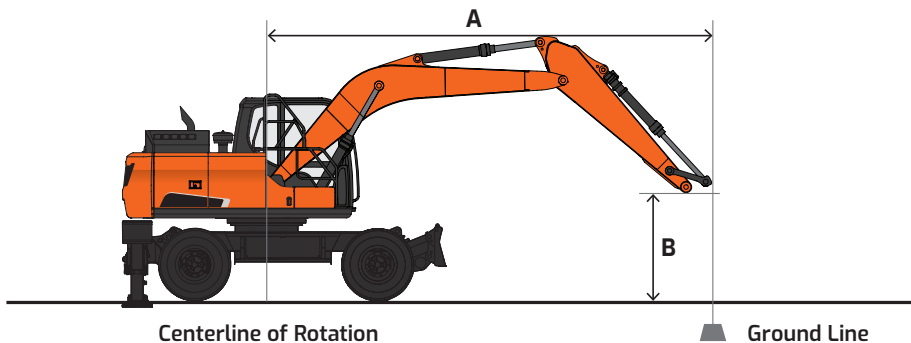













# Lifting Capacity

 Rating over front     Rating over side or 360°













## DX190W-7 US50

2-PC Boom: 18' 0" (5400 mm) | Arm: 7' 7" (2300 mm) | Counterweight: 7084 lb. (3220 kg) | Front & Rear Outriggers UP | Bucket: None | Unit: lb. (kg)

A (ft. or m) B (ft. or m)	5' (1.5 m)		10' (3.0 m)		15' (4.5 m)		20' (6.0 m)		25' (7.5 m)		Max. Reach		
													A
30' (9.0 m)											* 12080 (* 5480)	* 12080 (* 5480)	10.25' (3.12 m)
25' (7.5 m)					* 12400 (* 5630)	11630 (5270)					* 7580 (* 3440)	* 7580 (* 3440)	18.19' (5.55 m)
20' (6.0 m)					* 12600 (* 5720)	11500 (5220)	11040 (5010)	7240 (3290)			* 6380 (* 2890)	5890 (2670)	22.35' (6.81 m)
15' (4.5 m)					* 14950 (* 6780)	10850 (4920)	10800 (4900)	7030 (3190)			* 5890 (* 2670)	4880 (2210)	24.81' (7.56 m)
10' (3.0 m)					15990 (7250)	9930 (4500)	10390 (4710)	6650 (3020)	7410 (3360)	4750 (2150)	* 5750 (* 2610)	4420 (2000)	26.08' (7.95 m)
5' (1.5 m)					15160 (6880)	9210 (4180)	10000 (4540)	6300 (2860)	7270 (3300)	4610 (2090)	* 5880 (* 2670)	4280 (1940)	26.33' (8.03 m)
Ground Level					14840 (6730)	8930 (4050)	9770 (4430)	6100 (2770)	7200 (3270)	4550 (2060)	* 6290 (* 2850)	4430 (2010)	25.59' (7.80 m)
-5' (-1.5 m)					14870 (6750)	8960 (4060)	9770 (4430)	6090 (2760)			* 7450 (* 3380)	4960 (2250)	23.74' (7.24 m)

## DX190W-7 US50

2-PC Boom: 18' 0" (5400 mm) | Arm: 7' 7" (2300 mm) | Counterweight: 7084 lb. (3220 kg) | Front & Rear Outriggers DOWN | Bucket: None | Unit: lb. (kg)

A (ft. or m) B (ft. or m)	5' (1.5 m)		10' (3.0 m)		15' (4.5 m)		20' (6.0 m)		25' (7.5 m)		Max. Reach		
													A
30' (9.0 m)											* 12080 (* 5480)	* 12080 (* 5480)	10.25' (3.12 m)
25' (7.5 m)					* 12400 (5630)	* 12400 (5630)					* 7580 (* 3440)	* 7580 (* 3440)	18.19' (5.55 m)
20' (6.0 m)					* 12600 (* 5720)	* 12600 (* 5720)	* 11920 (* 5400)	* 11920 (* 5400)			* 6380 (* 2890)	* 6380 (* 2890)	22.35' (6.81 m)
15' (4.5 m)					* 14950 (* 6780)	* 14950 (* 6780)	* 12650 (* 5740)	* 12650 (* 5740)			* 5890 (* 2670)	* 5890 (* 2670)	24.81' (7.56 m)
10' (3.0 m)					* 18510 (* 8400)	* 18510 (* 8400)	* 14130 (* 6410)	13360 (6060)	* 12230 (* 5550)	9490 (4300)	* 5750 (* 2610)	* 5750 (* 2610)	26.08' (7.95 m)
5' (1.5 m)					* 21490 (* 9750)	20180 (9150)	* 15620 (* 7080)	12950 (5870)	* 12780 (* 5800)	9330 (4230)	* 5880 (* 2670)	* 5880 (* 2670)	26.33' (8.03 m)
Ground Level					* 22580 (* 10240)	19820 (8990)	* 16460 (* 7460)	12710 (5770)	* 12650 (* 5740)	9260 (4200)	* 6290 (* 2850)	* 6290 (* 2850)	25.59' (7.80 m)
-5' (-1.5 m)					* 21840 (* 9910)	19860 (9010)	* 16120 (* 7310)	12700 (5760)			* 7450 (* 3380)	* 7450 (* 3380)	23.74' (7.24 m)

A Distance from center of rotation

B Height

NOTE: Lifting capacities are in compliance with SAE 1097 and ISO 10567. Machine in lifting mode with power boost turned on. Load point is the end of the arm. Rated loads shown do not exceed 75% of minimum tipping loads or 87% of hydraulic capacities. Rated loads marked with an asterisk (\*) are limited by hydraulic capacities. The least stable position is over the side. The total mass of machine includes the mass of the boom, arm, counterweight, all operating fluids and 165 lb. (75 kg) operator.

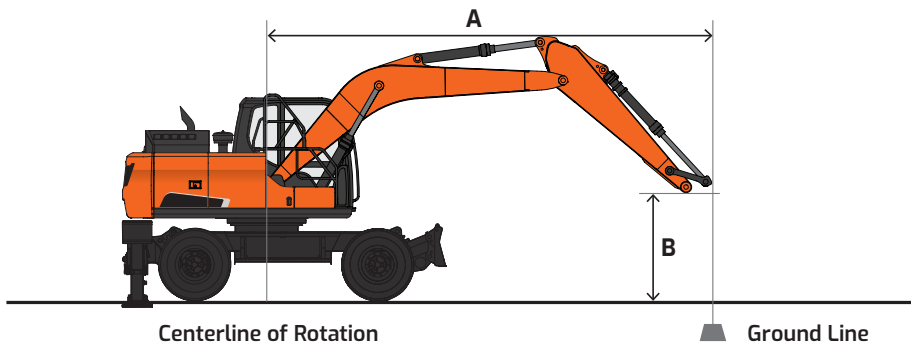



# Standard & Optional Equipment

■ Standard    ● Optional

## Engine

Emissions (EPA)	T4f
High-pressure common-rail (HPCR)	■
Turbo waste gate (WGT)	■
Cooled exhaust gas recirculation (CEGR)	■
Diesel oxidation catalyst (DOC)	■
Selective catalyst reduction (SCR)	■
Diesel exhaust fluid (DEF)	■
Fuel filter with water separator	■
Variable speed cooling fan (engine-driven with electric clutch)	■
Coolant expansion tank	■
Dual element dry-type air filter with evacuator	■
Precleaner	■
Electronic engine control (ECU)	■
Auto idle	■
Auto shutdown (time-adjustable)	■
Overheat & low oil pressure engine protection	■
Block heater (110 V), diesel-powered coolant heater	●
Water separator with heater	●
Fuel filler pump	●

## Hydraulic

Electronic Power Optimizing System (EPOS)	■
Variable axial piston main pump (tandem)	■
Cross-sensing pump control	■
Pilot-operated control valves	■
Gear pilot pump	■
Smart Power Control (SPC)	■
Axial piston swing motor	■
Spring-applied hydraulic release brake, travel	■
Spring-applied hydraulic release brake, swing motor	■
Axial piston travel motor (high/low, auto)	■
Auxiliary hydraulics, one- & two-way piping	■
Auxiliary hydraulics, tilt/rotate piping	●
Adjustable auxiliary flow & pressure, 10 presets	■
Boom & arm lock valves	●
Clamshell piping	●

## Controls

Steering wheel	■
Accelerator pedal	■
Brake pedal	■
Swing lock mechanism for traveling	■
Fine swing control	■
Joystick controls	■
Pattern control change valve (SAE, ISO BHL)	■
Joystick attachment control	■
Switches/buttons	■
- Right (one-way, two-way, power boost)	■
- Left (tilt/rotate, horn, one-touch decel)	■
Foot pedal attachment control	■
Control stands	■
- Height adjustable	■
- Sliding (fore/aft)	■
- Tilting armrests	■
Engine speed control dial	■
Switches & indicators, steering column	■
- Steering column	■
- Positional lever	■
- Work/travel selector switch	■
- Turn signal control lever	■
- Hazard warning switch	■
- Turn signal/hazard light indicators	■
- Wiper & washer control	■
- Horn button	■
- High/low beam control	■
Switches, console-mounted	■
- Starter button switch	■
- Travel speed selector	■
- Work light	■
- Auxiliary mode switch	■
Emergency stop switch	■
Power modes (P+, P, S, E)	■
Work modes (digging, lifting, breaker, shear)	■
Jog dial display control	■
Wiper control panel	■
Audio control panel	■

## Cabin

Steel, all-weather & sound-suppressed	■
ROPS (ISO 12117-2:2008)	■
Viscous mount with spring reinforcement	■
Front window panto wiper with wiper/washer	■
Tinted safety glass	■
Skylight top hatch with sun screen	■
Front window with sun screen	■
Visor – front window skylight & rear window	■
Pull-up type top front window	■
Removable lower front window with storage behind seat	■
Adjustable sliding side door window	■
Defrost, front window	■
Lockable doors	■
Seat	■
- Heated	■
- Air suspension	■
- 2" (51 mm) seat belt	■
- Adjustable height & recline	■
- Adjustable fore/aft	■
- Adjustable armrests	■
Leatherette seat	■
- Heating & cooling	■
- Air suspension	■
- 2" (51 mm) seat belt	●
- Adjustable height & recline	●
- Adjustable fore/aft	●
- Adjustable armrests	●
3" (76 mm) seat belt	●
Control stands	■
- Height adjustable	■
- Mounted to seat base	■
Foot rest	■
Storage for operator's manuals	■
Rearview mirrors	■
Fully automatic HVAC with radian energy photo sensor	■
8" multi-function LCD interactive display monitor	■
Cigarette lighter	■
Digital audio broadcasting radio with cell phone integration	■
Speakers (2)	■
Antenna, roof-mounted	■
Emergency breakout tool	■
Hot/cold beverage compartment	■
Power socket, 12 V & 24 V	■
Front & rear cup holders	■
Interior light	■
Coat hanger	■
Rain shield	●
Fog guard	●
Front window guard	●

## Electrical

System voltage – 24 V	■
Alternator – 24 V, 100 amp	■
2 x 12 V batteries, 150 AH reserve capacity, 950 CCA	■
Blade-type fuse panel	■
Main circuit breaker	■
Light, work (LED): machine (2), boom (2)	■
Light, work (LED): 6 cab top, front (4), rear (2)	●
Light, work (LED): 4 cab top, front (2), rear (2)	●
Rotating beacon	●
Hour meter	■
Engine restart prevention system	■
Side view camera with LED lamps (3)	■
Rearview camera with LED lamps (3)	■
360° all-around view camera	●
Microphone & speaker	●
Ultrasonic sensor	●
Laptop service port	■
Self-diagnostics system	■
Smart key (remote ignition key)	■
DEVELON Fleet Management	■

## Display Monitor & Warnings

Indicators	■
- Work modes (P+, P, S, E)	■
- User/Service menu	■
Gauges	■
- Fuel level	■
- DEF level	■
- Engine coolant temperature	■
- Hydraulic oil temperature	■
- Engine rpm	■
- Battery voltage	■
- Hydraulic pump pressure	■
- ECO	■
- Digital clock	■
- Trip meter	■
- Hour meter	■
- Fuel consumption	■
Warning & indicator lights	■
- Seat belt	■
- Error code	■
- SCR warning	■
- Check engine	■
- Engine oil pressure	■
- Engine pre-heat engaged	■
- Radiator coolant level & temperature	■
- Air filter	■
- Fuel level	■
- DEF level – low	■
- Water in fuel	■
- Battery charge	■
- Work lights on	■
- Hydraulic oil temperature	■
- Hydraulic charge pressure	■
- Hydraulic pilot filter	■
- Hydraulic return filter	■
Swing alarm	■
Travel alarm	■
Buzzer	■
- Engine oil pressure	■
- Coolant temperature	■

## Undercarriage

Tire size – 10.0 – 20 – 16 ply rating	■
Transmission 2-speed power-shift with creep	■
Planetary drive front & rear axle	■
Oscillating (±8°) front axle lockable	■
Steering front axle	■
Dozer	■
Outriggers, front (in place of dozer)	●
Outriggers, rear	■
Toolbox	■

## Other

Centralized lubrication	■
- Boom	■
- Swing	■
Emergency steering	■
Handrails & service platforms	■
Skid-resistant steps & service platforms	■
Wheel chocks	■
Manuals	■
- Operation & Maintenance	■
- Parts	■
- AEM Safety Manual	■
DEVELON Fleet Management 3-year subscription	■
Vandalism protection	■
- Lockable panels	■
- Lockable fluid fill points	■
- Anti-theft protection (password)	■
- Vandalism window cover mount	■
Air compressor	●

Certain specification(s) are based on engineering calculations and are not actual measurements. Specification(s) are provided for comparison purposes only and are subject to change without notice. Specification(s) for your individual DEVELON equipment will vary based on normal variations in design, manufacturing, operating conditions, and other factors. Pictures of DEVELON units may show other than standard equipment.

# Powered by Innovation

# DEVELON

A brand of HD Hyundai Infracore.

[na.develon-ce.com/dx190w-7](http://na.develon-ce.com/dx190w-7)

DX190W-7 Wheel Excavator Spec Sheet  
Printed in the U.S.A.  
23906\_002\_D041524

©2024 HD Hyundai Infracore. All rights reserved.