

DEVELON

-7 Series

Wheel Loaders

DL200-7 / DL200TC-7 / DL220-7 / DL250-7 / DL250TC-7 / DL280-7
DL320-7 / DL380-7 / DL420-7 / DL480-7 / DL550-7 / DL580-7



DEVELON

Continuous evolution, for better.

We trace our roots to 1937 as one of Korea's first large-scale machine plants. During that time, we have consistently delivered earth-moving equipment to build critical infrastructure for the betterment of communities, societies and the wider world.

We are
DEVELON.

DEVELON is a bold name that reflects our core ambition to continue developing onward and leaving behind a positive footprint in our world. Moving forward, we will continue providing innovative products and solutions that advance the world we live in today.



Your Local Dealer Is Dedicated to Your Success.

Your local DEVELON dealer is here for you: helping to solve your unique business challenges and advance the development of your community. Our dealers provide a full lineup of highly productive and fuel-efficient equipment, outstanding value and comprehensive services to help build your success.

Expanding Equipment Lineup

DEVELON continues to expand our innovative and durable lineup of equipment, providing more of the resources you need to take on a variety of projects and expand your business. Talk with your dealer to find the right equipment, attachments and technologies to move ahead.

Authorized DEVELON Service Technicians

You can count on experienced and highly skilled professional technicians from your local dealership to keep your valuable DEVELON equipment running at peak performance. You'll get responsive service, reliable parts and trusted advice.

Parts Availability

With two DEVELON-exclusive parts distribution centers in Georgia and Washington state, your dealer can offer more parts inventory and faster delivery — including less than two-day delivery on a majority of genuine DEVELON parts.

Machine Assembly Facility

A dedicated facility in Savannah, Georgia, tailors the equipment configuration and final machine assembly for faster delivery to your dealership.



Meet the Next Generation of DEVELON Wheel Loaders.

The redesigned lineup of -7 Series wheel loaders delivers the next generation of market-leading productivity, durability, operator comfort, fuel economy and versatility. Enhanced performance features and innovative technologies help you get the job done in the most challenging conditions, today and in the future.



Smart Technologies

- Transparent Bucket
- Optional Load Isolation System
- Smart Touch Display
- DEVELON Smart Guidance System
- Situation Awareness Technology (SAT)
- DEVELON Fleet Management
- Optional Around View Monitor (AVM) Camera System

Added Strength and Capacity

- 7% Larger Bucket Capacity
- Impressive Breakout Forces

Redesigned Cab

- 14% More Window Glass
- Relocated Controls for Easier Operation
- Improved Air Conditioning
- Smart Key
- Reversible Fan
- Rearview Camera

Improved Durability

- Outboard Brakes
- ZF Heavy-Duty Axles (all models except DL200-7) and Dana Heavy-Duty Axles (only DL200-7)
- Optional Rear Full Fenders

CONSTRUCTION
EQUIPMENT
Top 100
new products 2022

Awarded to DL220-7, DL280-7,
DL480-7 and DL580-7.

Power Through the Toughest Jobs.

DEVELON -7 Series wheel loaders cut big jobs down to size. With enough torque to bite into the toughest materials, they're built for rugged scooping, carrying and loading — and years of reliable performance.



Larger Bucket Capacity

Increased bucket capacity — up to 7% larger than the previous model — and larger axles increase lift capacity to help you load and move more material in fewer passes. So you can do more work in less time.

Fast Travel Speeds and Precise Acceleration

Planetary final drives transfer torque to the wheels to enable higher travel speeds and greater torque. The outboard, hub-mounted low-speed brakes make maintenance easy. The variable geometric turbocharger (VGT) optimizes boost pressure over a wide range of rpm to generate higher torque and faster response even at low rpm. It reduces "turbocharger lag" during acceleration, offers smoother, precise response to accelerator movement and lowers fuel consumption.

The automatic powershift torque converter transmission improves powertrain efficiency in load-and-carry operations, which contributes to improved fuel efficiency.

The optional torque converter lockup clutch enables nearly 100% torque transfer directly from the engine to the transmission for quicker acceleration and climbing uphill.

- Increases productivity up to 20% in stockpiling applications.
- Improves gear shifting for faster cycle times during truck loading.
- Boosts high-gear performance during load-and-carry operations.

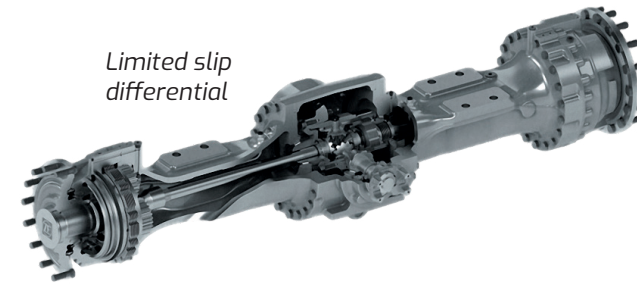

Limited slip differential

Outstanding Traction and Pushing Power

The limited slip differential allows the wheel with the most traction to receive the proper torque, providing superior tractive effort and maneuverability in tough terrain.

The optional front-locking differential locks the front wheels together, providing superior traction for driving over loose, slippery terrain or pushing into big, heavy piles.

Improved Transmission Performance

Choose the transmission mode you want for the working conditions you face.

- Manual is ideal when the job requires precise speed control.
- Auto 1-4 automatically shifts up when you need more speed and downshifts when the job demands more power or torque. It's excellent for heavy-duty applications.
- Auto 2-4 with Manual Kickdown gives you automatic shifting between gears 2 through 4, with a manual downshift into first gear when you need it. It provides the best performance for less demanding work conditions.

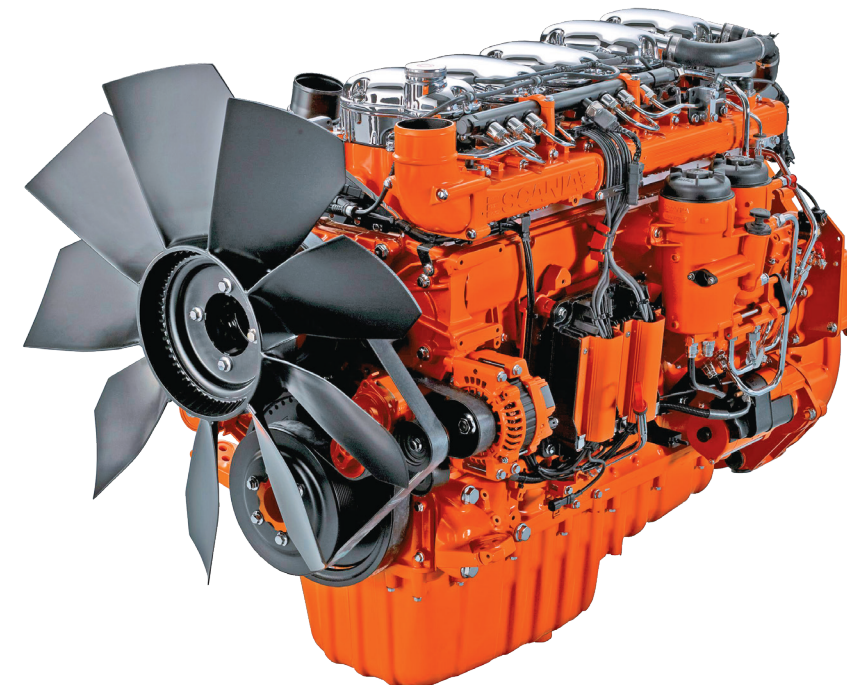

Optimized Engine Horsepower

Finely tuned horsepower curve and higher torque ensure that you can move mountains of material fast. A high-pressure common-rail (HPCR) fuel injection system and cooled exhaust gas recirculation (CEGR) valve reduce emissions.

Fuel-Efficient and Tier 4 Compliant

To comply with Tier 4 emissions standards, -7 Series wheel loaders incorporate a high-pressure common-rail fuel delivery system as well as cooled exhaust gas recirculation, combined with a diesel oxidation catalyst (DOC) and selective catalyst reduction (SCR) with diesel exhaust fluid (DEF).

Work More Efficiently. Finish More Work.

There's no secret to doing more work in less time. You have to quickly and efficiently handle the biggest, heaviest load that you can. DEVELON wheel loaders give you the advantage with the right technologies to help you work more efficiently without sacrificing productivity on today's demanding job sites.



Efficient Power Management

Three Engine Power Modes

Choose Power, Normal or Economy mode to further adapt your loader's performance to the application and deliver the right balance of power and fuel economy.

- **Power mode** delivers the highest level of performance for quick loading and fast travel.
- **Normal mode** is ideal for general work conditions and optimal fuel consumption.
- **Economy mode** minimizes fuel consumption and reduces engine sound levels for comfortable, economical light-duty work.

Situation Awareness Technology (SAT)

To boost machine performance and fuel efficiency, Situation Awareness Technology automatically monitors your wheel loader's activity and adjusts engine output to match real-time requirements of the hydraulic system and drivetrain – whether you're loading, lifting or hauling. It lowers fuel consumption without reducing performance.

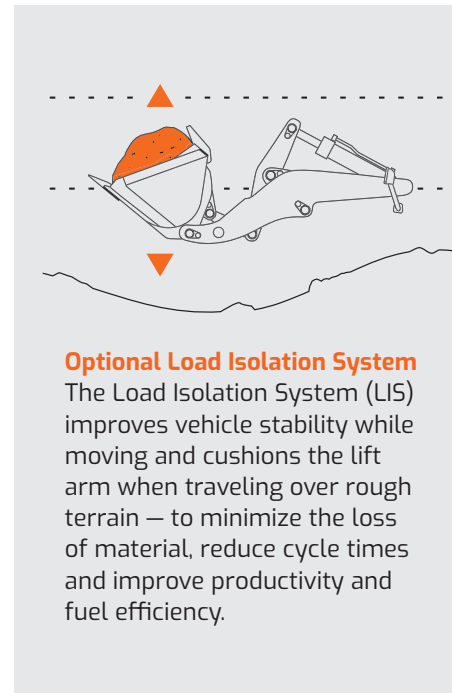

Optional Load Isolation System

The Load Isolation System (LIS) improves vehicle stability while moving and cushions the lift arm when traveling over rough terrain – to minimize the loss of material, reduce cycle times and improve productivity and fuel efficiency.



Tips for Efficient Operation

DEVELON Smart Guidance System (DSGS) helps operators achieve the most fuel-efficient operation possible by analyzing driving habits and providing tips during operation to help improve their productivity.

DEVELON Smart Load

The DEVELON Smart Load weighing system is ideal for job applications that require accurate information about material weight in the bucket. All menus and settings are integrated in the Smart Touch display.

Reduced Idle Time

Conserve fuel and save money. A standard auto-idle feature reduces engine rpm when the steering wheel or joystick isn't being used. Simply move the controls and the loader will automatically return to working idle.

When auto shutdown is enabled, the engine shuts down after idle time reaches a specified elapsed time – from 3 to 60 minutes – which can be set from the Smart Touch display.



Heavy-Duty Performance in Extreme Conditions.

DEVELON wheel loaders rank among the toughest and most profitable in the industry. But because your jobs and working conditions aren't getting easier, we added new levels of durability to our -7 Series models to maximize uptime in the most extreme conditions.



Updated Axles

- Updated axles support larger bucket capacities and offer better braking capacity to extend the lifetime of the disks. All models except DL200-7 feature ZF heavy-duty axles. The DL200-7 features Dana heavy-duty axles.
- The axle cooler on the DL580-7 improves reliability for applications like carrying loads long distances or working in high ambient temperatures.

- Increased durability of the box frame was achieved using the latest computer-aided structure analysis to add material to key sections for better balance and improved lifting capacity.
- The frame's articulating design provides excellent load distribution and rigidity for improved structural life.



Heavy-Duty Components

- Thick, solid-steel lift arm plates provide maximum durability in harsh conditions — along with improved lift capacities.
- Large, self-centering, double-tapered roller bearings distribute vertical and horizontal loads in the articulation joint over a larger area.
- Dust seals and covers are vented to prevent grease overflow.
- Lift arm pins are protected with bushings and dust covers to increase pin life and reduce maintenance.
- All-steel access panels allow easy maintenance access while protecting critical engine, hydraulic and electrical components.

Automatic Central Lubrication System

An available automatic lubrication system offers improved machine reliability and saves daily maintenance time. Grease is delivered at the middle of the pin and bushings for better grease distribution.

Outboard Brakes

Brakes are located on the outboard side of the wheel hub after final reduction where the rotation speed is lower. The discs are exposed to lower rpm and heat generation is reduced, greatly extending the lifetime of the brake discs with simple maintenance access.

Dynamic Braking

The operator can slow the wheel loader without touching the brakes, even when traveling on an incline. Easing up on the gas decreases flow to the motors so that the loader slows down. (Standard on DL200-7 hydrostatic transmission (HST) model only.)

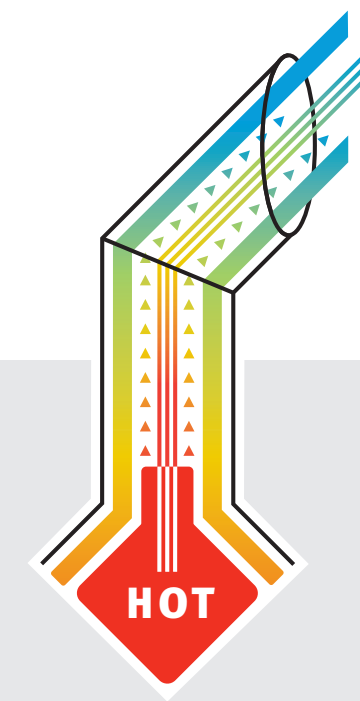

Reliable Cooling System



Radiator With 40% Wider Fin Spacing

A new radiator with wider fin spacing on some models quickly clears dirt, dust and other large debris to reduce clogging while keeping the cooling system performing consistently — to minimize machine downtime in scrap, forestry and agriculture applications.

Variable-Speed and Reversible Cooling Fans

The hydraulically driven, variable-speed cooling fan slows and speeds up as required by the work demands of your loader. In lighter-duty conditions, the coolant temperature is low and the fan slows — saving fuel and extending the life of your cooling system.

A standard reversible cooling fan is adjustable from the Smart Touch display to assist in keeping the cooling system clean in extremely dusty applications. Auto reverse setting runs the fan for a few minutes at a time at different intervals.

Exhaust Heat Exchanger and Separate Engine/Cooling Compartments

The exhaust heat exchanger helps your engine and cooling system run more efficiently. This design creates a vacuum that pulls hot air out of the engine compartment. In addition, the engine and cooling system are isolated to increase cooling efficiency and extend the life of engine components.

Take Complete Control in Total Comfort.

New -7 Series wheel loaders are designed to give operators the comfort, innovative features and ease of operation they asked for. We relocated controls, improved visibility and added standard technologies to help operators do their best work.



Smart Touch Display

The standard, user-friendly Smart Touch touch screen displays all important settings and information on one screen. From the touch screen, operators can monitor critical machine functions and control machine settings, rearview camera, heating and cooling, the DEVELON Smart Guidance system and more.



Industry-Exclusive Transparent Bucket

This standard -7 Series wheel loader feature increases overall visibility to promote safer worksite conditions. Operators can "see through" the bucket from a monitor inside the cab for an unobstructed view in front of the bucket.

The optional **around view monitor (AVM)** camera system displays a full view of the machine's surroundings for greater confidence when operating the machine in tight work areas.

The standard **rearview camera** provides an additional view of the machine's surroundings from the Smart Touch display

Glass area is 14% larger, and a full glass door improves visibility on the left side. Larger, heated mirrors extend the operator's view to the side and rear of the machine, and LED work lights make it easier for operators to see and work in low-light areas.

Improved Operator Environment

To improve productivity and safety, and reduce operator stress, the cab interior was redesigned with a much roomier, quieter and more comfortable environment.

- Frequently used controls, including the joystick, are relocated within easy reach for more intuitive operation.
- An upgraded automatic heating and air conditioning system — along with adjustable vent locations positioned to maximize heating and cooling efficiency in the cab — keeps operators comfortable when working long days. Simply set the desired temperature and airflow for all-day comfort.
- An air-suspension seat with multiple adjustment points and telescoping tilt steering allows operators to select an optimal working position for improved ergonomics and comfort for their entire shift.
- Grab handles and offset steps with slip-resistant surfaces provide easy access to the cabin and easy exit when work is finished.



Joystick Controls

Direction changes don't get any simpler. Just push the joystick buttons to switch between forward, neutral and reverse without even removing your hands from the controls.

Optional electronic steering on select models allows operators to control direction and steer the machine with switches comfortably integrated into the left armrest. The controls can be customized to the operator's sensitivity preferences.



Standard Smart Key

The Smart Key brings automotive convenience to construction equipment. The simple, smart key fob unlocks the cab and allows push-button engine starts.

New Challenge? No Problem.

Maximize your investment with a versatile DEVELON wheel loader that can finish a variety of jobs and tasks. Add one of our rugged attachments that are matched to the loader's operating weight and load settings to do even more.

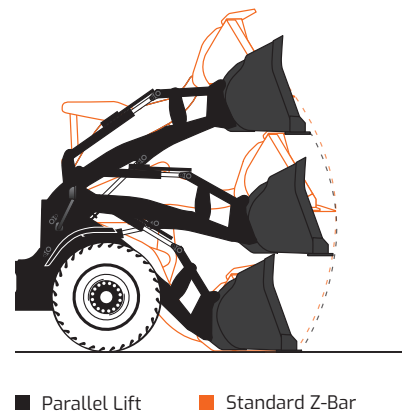
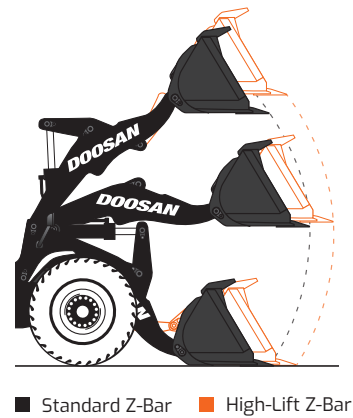

Lift Arm Options

Z-Bar Lift Arm Linkage is designed for heavy lifting and loading applications, with geometry that enables rapid bucket movement and proper angle positioning in every situation.

Standard Z-Bar Linkage has excellent breakout forces for easier digging and penetration into tough materials. It increases the lifting capacity of every DEVELON loader for best-in-class performance.

High-Lift Z-Bar is ideal when higher lift applications are the priority with bucket capacities of similar size.

Parallel-Lift Linkage system on tool carrier models gives you precise control over a variety of attachments in applications other than loading, such as lift-and-place-type applications. It keeps the attachment level, allowing for faster lifting and placing of materials.



Optional Counterweight

For the flexibility to tackle a variety of applications, an optional larger counterweight can be added to improve machine balance.

Auxiliary Hydraulics

For hydraulic attachments, an auxiliary spool comes standard with hydraulic piping routed to the base of the lift arm. Hydraulic lines to the end of the lift arms are optional.

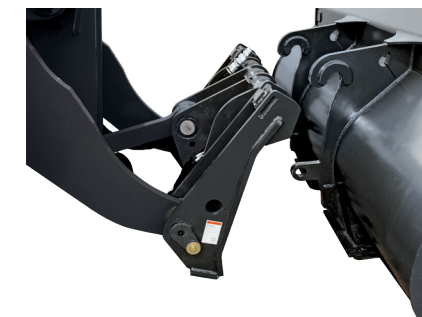

Optional Quick Coupler

The optional quick coupler allows you to quickly change many of your wheel loader's non-hydraulic attachments without leaving your seat. The four-point-style pickup means you can hook up attachments easily, even on irregular terrain.

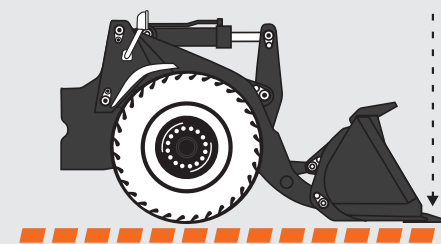

Return to Dig

Sensors on the lift arm and bucket linkage allow you to change your "return to dig" setting. The cylinders and cutting edge return to the same position every time, enabling more efficient, consistent work.

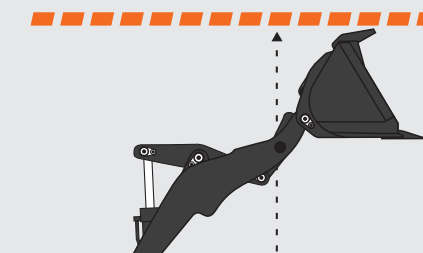

Lift Kickout

Set the maximum lift height for working inside buildings or other areas with height restrictions. Simply pull back on the control stick to override.

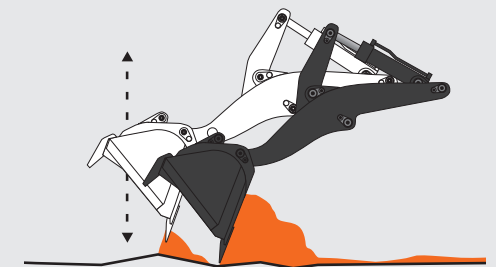

Boom Float

The boom float allows your bucket to follow the ground contours, which saves you time and increases productivity when backdragging during snow removal.

Regular Maintenance Made Easy.

If it's easy to do, regular maintenance gets done. That's how DEVELON approaches its wheel loader design. Excellent durability, centrally located maintenance points, onboard diagnostic systems and easy component access deliver low-effort maintenance and long-lasting performance.



Easy Component Access

- Big, easy-to-open steel access covers and fold-up panels provide fast, ground-level access to critical engine and hydraulic components.
- The rear-mounted cooling system pulls in cooler and cleaner air for maximum efficiency. For easier cleaning access, the rear screen flips up and the hinge-mounted fan swings out.
- Convenient access to remote drain ports makes for fast, convenient exchanges of engine oil and cooling system coolant, and the easy DEF tank fill ensures that your T4-compliant DEVELON machine operates at its full potential with fewer harmful emissions. Fluids, including oils, coolant and DEF, are available from your DEVELON dealer in various container sizes.



Local Service and Parts

Your local DEVELON dealer offers exceptional service from factory-trained technicians. You can also pick up genuine DEVELON parts from your dealer, who is supported by two regional warehouses located in North America.

Quick, Easy Machine Diagnosis

Self-diagnostics allow you to monitor critical systems in real time and access historical machine alerts right from the Smart Touch screen in the cabin.

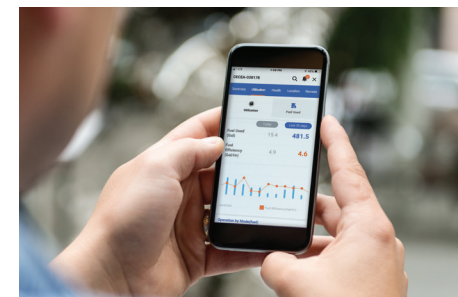

DEVELON Fleet Management

This system gives your dealer a direct communications link with your wheel loader. During operation, it monitors all critical data and provides a complete history of operation and a real-time log of machine failures. Armed with information like this, your dealer service personnel can fix issues fast – and you can get back to work.

Convenient Maintenance Features

Color-coded, labeled wiring and hydraulic hoses enable plug-and-play installation of electrical accessories – such as the optional rotating beacon – and allow quicker, easier electrical troubleshooting.

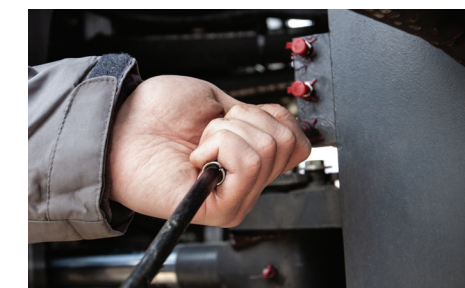

Centralized lubrication points make daily greasing more likely to get done. Remote grease points make it easier to lubricate hard-to-reach pins on the lift arm and articulation system.



Sight glasses make it easy to check major fluid levels. With a quick glance you'll know if your fluid reservoirs are properly filled.

FULL COVERAGE

36 MONTHS **5K** HOURS

Superior Standard Warranty

Your new DEVELON machine includes full coverage for 36 months or 5,000 hours, whichever comes first, with parts and service support from your local authorized DEVELON dealer.

Protection Plus® Extended Warranty

Our DEVELON Protection Plus® extended warranty coverage offers up to 420 different plan options, allowing you to customize coverage to meet your needs. Purchase up to 72 total months or up to 10,000 total hours of warranty protection covering the full machine, powertrain or powertrain plus hydraulics.

› Heavy-Duty Axles › DEVELON Fleet Management › Smart Touch Display › Rearview Camera › Auxiliary Hydraulic Spool and Piping › Smart Key



Premium Features Come Standard on DEVELON -7 Series Wheel Loaders.

To compete and succeed, your equipment needs to maximize job site productivity and the bottom line. DEVELON machines do both. To ensure a high return on investment, we add more premium features as standard equipment on every model.

These features are often options that come with an additional cost from other manufacturers. By including them as standard, DEVELON gives you a competitive edge — helping operators work more efficiently and improving safety during the longest workdays.

Heavy-Duty Axles

Strong axles increase lift capacity to help load and move more material.

- All -7 Series wheel loaders, except the DL200-7, offer heavy-duty ZF axles.
- The DL200-7 features heavy-duty, durable Dana axles.

DEVELON Fleet Management

Power telematics system makes it easy to remotely monitor and maintain your machine. It keeps track of the health, location and productivity of the equipment from a user-friendly app and website.

Smart Touch Display

An easy-to-read, user-friendly multilingual touch screen displays all important settings and information including the rearview camera view. Operators can monitor critical wheel loader functions and control machine settings.

Rearview Camera

The rearview camera provides the operator with an additional view of the wheel loader's surroundings, increasing confidence and productivity.

Auxiliary Hydraulic Spool and Piping

Hydraulic piping is routed to the base of the lift arm.

Smart Key

The Smart Key fob unlocks the cab and allows push-button engine starts for operator convenience.

Monitor Your Equipment From Anywhere.

DEVELON Fleet Management is a powerful equipment diagnostic tool that monitors the health, location and productivity of your DEVELON equipment from a user-friendly mobile app and website. It offers free monitoring with no contract and no fees.



Scan the Code
Learn more about how DEVELON Fleet Management can help you take care of your valuable DEVELON equipment.

With DEVELON Fleet Management, you can:

- Help prevent theft with geofencing feature (GPS location tracking).
- See when maintenance is due.
- Customize alerts to your schedule.
- Track oil pressure, operating temperature and more.
- Use data to train your team for maximum productivity.

The data is uploaded automatically to the DEVELON Fleet Management online system using dual-mode communications (cellular and satellite) for maximum coverage. You can check on machine status from anywhere using the DEVELON Fleet Management website and mobile application. Your dealer can also see your equipment status to notify you when it's time for service.

SMART X CARE

Let us do the work for you to help protect your equipment investment. DEVELON Smart X-Care™ service gives you peace of mind knowing our experienced team is tracking your machine telematics and providing recommendations. **Talk to your dealer to learn more.**

Attachments

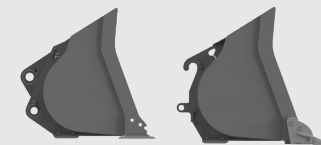

General Purpose Bucket

Designed with a sloped bottom for maximum filling while retaining material and improving dump angle, this is the perfect bucket for day-to-day material handling.

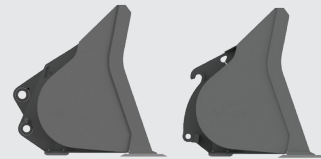

Light Material Bucket

Designed for material densities less than 2,000 lb./yd³ (1185 kg/m³). Utilize with lighter-weight materials such as mulch, snow or crushed asphalt to maximize efficiency.



Grapple Bucket

Optimized for land waste or recycling operations or land clearing. Grab and secure a wide range of material sizes and easily capture large, odd-sized items with the half-side design and the two independent grapple arms.

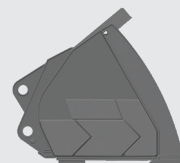

Aggregate Bucket

Designed with a flat bottom for an optimal cut into a pile to provide maximum filling and machine efficiency. Standard spill guard protects hydraulic lines and machine linkage from falling debris.



Rock Bucket

Designed for heavy-duty digging applications. Features a spade nose style for improved digging and bucket filling in the toughest heavy-duty applications.



Pallet Fork

Easily lift, carry and place construction materials on your worksite. Fork design offers improved center of gravity for better load control and handling.



Quick Coupler

Quickly change your non-hydraulic wheel loader attachments without leaving your seat.

Certain specification(s) are based on engineering calculations and are not actual measurements. Specification(s) are provided for comparison purposes only and are subject to change without notice. Specification(s) for your individual DEVELON equipment will vary based on normal variations in design, manufacturing, operating conditions, and other factors. Pictures of DEVELON units may show other than standard equipment.

Powered by Innovation

DEVELON

A brand of HD Hyundai Infracore.

na.develon-ce.com/wheelloader

Wheel Loader Brochure
Printed in the U.S.A.
23910_006_D022124

©2024 HD Hyundai Infracore. All rights reserved.