

# DEVELON

## Wheel Loader

# DL280-7



### Engine

Make	DEVELON
Model	DL06
Number of cylinders	6
Rated power, gross (hp per SAE J1995)	189.1 hp (141.0 kW) @ 2000 rpm
Rated power, net (hp per SAE J1995)	189.1 hp (141.0 kW) @ 2000 rpm
Max. torque, gross (SAE J1995)	665.4 lbf. ft. (92.0 kfg) @ 1400 rpm
Displacement	360.0 in. <sup>3</sup> (5.9 L)
Bore and stroke	3.9" x 4.9" (100 mm x 125 mm)
Starter	24 V, 8.6 hp (6.0 kW)
Battery	2 x 12 V, 100 AH, 900 CCA
Alternator	24 V, 80 A
Air cleaner	Double elements

### Hydraulics

Main pumps	Variable displacement axial piston pump 65.0 gpm (246.0 L/min.)
System pressure (work)	3843.5 psi (265.0 bar)
System pressure (steer)	2828.2 psi (195.0 bar)
Boom speed – up	5.4 sec
Boom speed – down	3.2 sec
Bucket speed – crowd	1.7 sec
Bucket speed – dump	1.5 sec

### Travel Speeds

Travel speed – forward (4-speed)	3.9 / 7.7 / 14.4 / 22.1 mph (6.3 / 12.4 / 23.1 / 35.6 km/h)
Travel speed – forward (5-speed) (US15 package only)	4.1 / 7.3 / 11.1 / 17.8 / 24.9 mph (6.6 / 11.7 / 17.9 / 28.7 / 40 km/h)
Travel speed – reverse (4-speed)	4.1 / 8.1 / 15.0 mph (6.6 / 13.0 / 24.2 km/h)
Travel speed – reverse (5-speed) (US15 package only)	4.3 / 7.6 / 18.1 mph (7.0 / 12.3 / 29.2 km/h)
Max. grade	58% (30°)

### Environment

Sound level (ISO 6395)	104 dB(A)
Cabin sound level (ISO 6396)	71 dB(A)

### Refill Capacities

Fuel tank	62.1 gal. (235.0 L)
DEF tank	7.9 gal. (30.0 L)
Cooling system (radiator capacity)	9.0 gal. (34.0 L)
Engine oil	6.5 gal. (24.5 L)
Transmission	9.8 gal. (37.0 L)
Front axle	9.2 gal. (35.0 L)
Rear axles	9.2 gal. (35.0 L)
Hydraulic system	31.7 gal. (120.0 L)

All capacities are approximate values. Always refer to the machine's OM for exact refill levels. Check the dipstick, level eye, level plug, etc., to achieve the correct level.

### Hydraulic Cylinders

Steering (2) bore x rod diameter x stroke	2.8" x 1.8" x 18.3" (70 mm x 45 mm x 466 mm)
Lift arm (2) bore x rod diameter x stroke	5.3" x 3.1" x 31.1" (135 mm x 80 mm x 790 mm)
Bucket (1) bore x rod diameter x stroke	6.3" x 3.7" x 20.1" (160 mm x 95 mm x 510 mm)

The piston rods and cylinder bodies are made of high-strength steel. A shock-absorbing mechanism is fitted in at the base and rod end of the lift and bucket cylinders and the rod end of the steering cylinders to ensure shock-free operation and extended piston life.

# Dimensions

		Standard Arm	High-Lift
Bucket capacity, heaped ISO/SAE		3.7 yd <sup>3</sup> (2.8 m <sup>3</sup> )	
Bucket width	A	8' 11.9" (2740 mm)	
Max. hinge pin height	B	12' 11.6" (3952 mm)	14' 5.0" (4395 mm)
Dump height (45°) – fully raised	C	9' 3.0" (2820 mm)	10' 9.1" (3280 mm)
Dump reach (45°) – fully raised	D	3' 9.7" (1160 mm)	3' 8.3" (1125 mm)
Digging depth	E	4.5" (115 mm)	8.0" (203 mm)
Overall height, ROPS cabin	F	11' 0.3" (3360 mm)	
Overall length	G	25' 1.3" (7655 mm)	26' 5.9" (8075 mm)
Wheel base	H	10' 0.0" (3050 mm)	
Tread width	I	6' 8.3" (2040 mm)	
Ground clearance	J	1' 3.7" (400 mm)	
Max. tilt angle on ground*		43°	40°
Max. tilt angle at carry position	K	49°	48°
Max. tilt angle at fully raised	L	61°	58°
Max. dump angle at fully raised	M	46°	45°
Max. steering angle	N	40°	
External turning radius, bucket edge	O	20' 1.9" (6145 mm)	20' 8.0" (6300 mm)
External turning radius, outside tire	P	18' 1.0" (5510 mm)	
Tire size		20.5R25 L3	
Operating weight		34550 lb. (15672 kg)	34892 lb. (15827 kg)
Static tipping load (straight)		27064 lb. (12276 kg)	22180 lb. (10061 kg)
Static tipping load (at full turn)		23857 lb. (10821 kg)	19553 lb. (8869 kg)
Breakout force		32822 lbf. (146.0 kN)	28776 lbf. (128.0 kN)

\*Not shown on diagram

## Front Lift Arm Configuration

Standard: U510, U511, U515, U530

High-Lift: U520, U521, U540

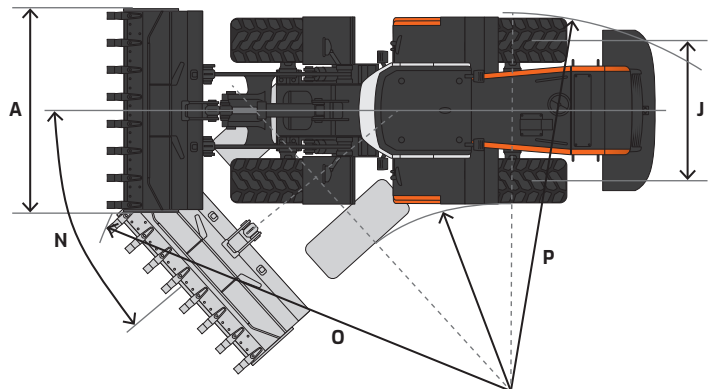
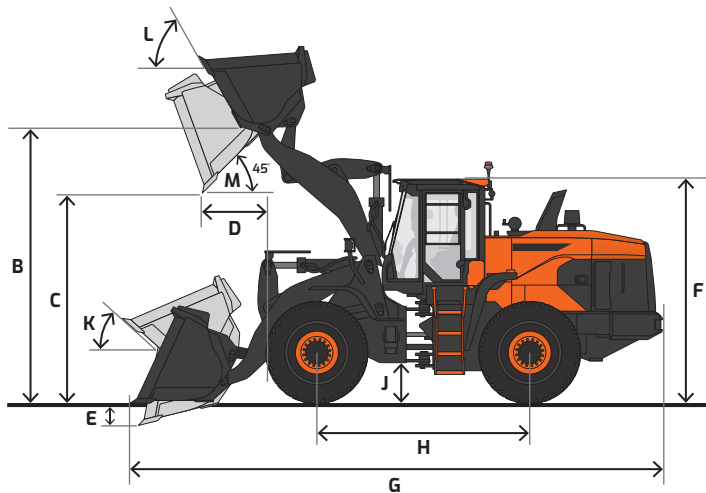

# Standard & Optional Equipment

Standard Base Package, US10

■ Standard    ● Optional

## Engine

Emissions (EPA), T4f	■
High-pressure common-rail (HPCR)	■
Turbo, variable geometry (VGT)	■
Cooled exhaust gas recirculation (CEGR)	■
Diesel oxidation catalyst (DOC)	■
Selective catalytic reduction (SCR)	■
Diesel exhaust fluid (DEF)	■
Fuel filter with water separator	■
Coolant recovery tank	■
Dual element dry-type air filter with evacuator	■
PreCleaner	■
Electronic engine control (ECU)	■
Auto idle (working to standby)	■
Auto shutdown (time adjustable)	■
Overheat & low oil pressure engine protection	■
Cooling fan – radiator, variable speed	■
Cooling fan – radiator, automatic reversible	■
Remote drain port – engine oil	■
Block heater (110 V)	■

## Hydraulic

Variable displacement axial piston pump	■
Closed-center system	■
Main control valves, pilot	■
Main control valves, electric	●
Remote test ports	■
Remote drain port, hydraulic oil	■
Auxiliary hydraulics (3rd valve)	■
Auxiliary hydraulic detent (EMCV only)	●
Automatic boom/lift kick-out, adjustable (in cab)	■
Automatic return-to-dig position, adjustable	■
Automatic return-to-dig position, adjustable (in cab, EMCV only)	●
Boom float	■
Ride control	■

## Electrical

System voltage – 24 V	■
Alternator – 24 V, 80 A	■
2 x 12 V batteries, 100 AH reserve capacity, 900 CCA	■
Blade-type fuse panel	■
Main circuit breaker	■
Lights, work (LED): front (2), rear (2)	■
Lights, work (LED): front (4), rear (4)	●
Lights, work (LED): front (6), rear (6)	●
Lights, headlights (halogen): hi/lo beams (2)	■
Lights, stop, tail & direction indicators	■
Horn	■
Rotating beacon	■
Hour meter	■
Engine restart prevention system	■
Rearview camera	■
Laptop service port	■
Self-diagnostics system	■

## Cabin

Steel, all-weather & sound-suppressed	■
ROPS (ISO 3471)	■
FOPS (ISO 3449)	■
Front window with wiper/washer	■
Rear window with wiper	■
Tinted safety glass	■
Visor, retractable	■
Adjustable sliding side door window	■
Defrost, front window	■
Lockable doors	■
Seat	■
- Air-suspension	■
- 3" (76 mm) seat belt	■
- Adjustable height & recline	■
- Adjustable fore/aft	■
- Adjustable armrests	■
Control stands	■
- Height adjustable	■
- Fore/aft adjustable	■
Control stands	●
- Integrated with seat	●
Storage for operator's manuals	■
Mirror, interior rear view (1)	■
Mirrors, exterior (2), heated	■
Mirrors, exterior (2), heated (electronic adjustable)	●
Fully automatic HVAC with ambient temperature sensor	■
Smart Touch display	■
- 8" touch-enabled	■
- Adjustable height & angle	■
Transparent Bucket	■
- Multi-camera system & controller	■
- In-cab display	■
AM/FM stereo with CD player & MP3 port	■
Speakers (2)	■
Antenna, roof-mounted	■
Emergency breakout tool	■
Power socket, 12 V	■
Power socket, USB	■
Cup holder	■
Interior light	■
Coat hanger	■

## Controls

Adjustable steering column	■
- Tilting	■
- Telescoping	■
Emergency secondary steering	●
Throttle pedal (accelerator)	■
Brake pedal, right	■
Brake pedal, left	■
Brake pedal transmission kick-out	■
Gear selector (FNR)	■
Joystick control	■
Switches, console-mounted	■
- Starter (button)	■
- Parking brake	■
- Pilot cutoff	■
- Transmission cutoff	■
- Work light	■
- Reversible cooling fan	■
Emergency stop switch	■
Power mode (P, S, E)	■
Transmission mode (manual, auto 1-4, auto 2-4)	■
Wiper control panel	■
Audio control panel	■

## Display Monitor & Warnings

Buzzer	■
- Engine oil pressure	■
- Coolant temperature	■
- Transmission overheat	■
Gauges	■
- Fuel level	■
- DEF level	■
- Engine coolant temperature	■
- Transmission oil temperature	■
- Engine rpm	■
- Speedometer	■
- Transmission gear indicator	■
- Battery voltage	■
- ECO	■
- Smart guidance system	■
- Digital clock	■
- Trip meter	■
- Hour meter	■
- Total operation time	■
- Fuel consumption	■
Warning & indicator lights	■
- Seat belt	■
- Error code	■
- SCR warning	■
- Check engine	■
- Engine oil pressure	■
- Engine pre-heat engaged	■
- Radiator coolant level & temperature	■
- Air filter	■
- Fuel level	■
- DEF level – low	■
- Water in fuel	■
- Battery charge	■
- Direction signal	■
- Lights (high, main, work, beacon)	■
- Emergency steering	■
- Hydraulic oil temperature	■
- Hydraulic charge pressure warning	■
- Hydraulic pilot filter	■
- Hydraulic return filter	■
- Transmission mode	■
- Transmission warning	■
- Transmission lock-up	■
- Transmission oil temp	■
- Transmission gear indicator	■
- Brake fluid pressure warning	■
- Reverse fan indicator	■
- Mirror heat indicator	■
- Parking brake indicator	■
Back-up alarm	■
Scale system, integrated smart scale	●
Around view monitor (AVM)	●

## Frame & Driveline

Z-bar lift arm	■
Z-bar lift arm, high-lift	●
Steering cylinders, double-acting (2)	■
Transmission – 4F/3R speed	■
- Full automatic – power shift	■
- Torque converter	■
Transmission – 5F/3R speed	●
- Automatic – power shift	●
- Torque converter lock-up clutch	●
Differentials	■
- Limited slip front/rear	■
Differentials	●
- Hydraulic locking front	●
- Open rear	●
Hydraulic power steering	■
Outboard planetary axles	■
Outboard planetary axles – heavy-duty	●
Fixed front axle	■
Oscillating rear axle	■
Spring-applied hydraulic release brake	■
Sealed, self-adjusting brakes	■
Tires, 20.5R25 L3 radial standard	■
Outboard brakes	■

## Other

Centralized lubrication	■
Air-compressor	●
Handrails, entrance & service steps	■
Handrails, roof-mounted	■
Skid-resistant entrance steps	■
Skid-resistant service platforms	■
Drawbar and pin	■
Wheel chocks	■
Rear fender, full	●
Additional counterweight*	■
Manuals	■
- Operation & Maintenance	■
- AEM Safety Manual	■
MY DEVELON (telematics)	■
Vandalism protection	■
- Lockable panels	■
- Lockable fluid fill points	■
- Anti-theft protection (password)	■

\*Standard on high-lift models

Certain specification(s) are based on engineering calculations and are not actual measurements. Specification(s) are provided for comparison purposes only and are subject to change without notice. Specification(s) for your individual DEVELON equipment will vary based on normal variations in design, manufacturing, operating conditions, and other factors. Pictures of DEVELON units may show other than standard equipment.

# Powered by Innovation

# DEVELON

A brand of HD Hyundai Infracore.

[na.develon-ce.com/dl280-7](http://na.develon-ce.com/dl280-7)

DL280-7 Wheel Loader Spec Sheet  
Printed in the U.S.A.  
23906\_005\_D100224

©2024 HD Hyundai Infracore. All rights reserved.