

DEVELON

Mini Excavator

DX35Z-7



Engine

Make	DEVELON
Model	DN1.7
Number of cylinders	3
Rated power, gross (hp per SAE J1995)	24.7 hp (18.4 kW) @ 2200 rpm
Rated power, net (hp per SAE J1349)	24.1 hp (18.0 kW) @ 2200 rpm
Max. torque, net (SAE J1995)	72.0 lbf.-ft. (9.9 kgf-m) @ 1600 rpm
Displacement	101.0 in. ³ (1.65 L)
Bore and stroke	3.4" x 3.6" (87 mm x 92.4 mm)
Starter	12 V, 2.3 hp (1.7 kW)
Battery	12 V, 55 AH
Alternator	13.5 V, 75 A
Air cleaner	Double elements

Hydraulics

Main pumps	2 x 10.0 gpm (37.0 L/min.)
Pilot pump (gear design)	3.0 gpm (11.0 L/min.)
Relief pressure	3983.0 psi (280.0 kg/cm ²)

Maximum System Pressure

Boom/arm/bucket (normal mode)	3553.0 psi (250.0 kg/cm ²)
Swing (crossover relief)	3129.0 psi (220.0 kg/cm ²)

Undercarriage

Upper rollers (each track)	1
Lower rollers (each track)	4
Number of shoes (links per side)	Single assembly (rubber)

Swing Mechanism

Swing speed	8.3 rpm
Swing torque	6280.0 lbf.-ft. (868.0 kgf-m)

Drive System

Travel speed (low – high)	1.6 – 2.7 mph (2.5 – 4.3 km/h)
Traction force, max. (drawbar pull)	9851.0 lbf. (4468.0 kgf)
Max. grade	58% (30°)

Environment

Sound level (ISO 6395)	94 dB(A)
Cabin sound level (ISO 6396)	78 dB(A)

Refill Capacities

Fuel tank	9.5 gal. (36.0 L)
Cooling system (radiator capacity)	1.3 gal. (4.8 L)
Engine oil	1.5 gal. (5.8 L)
Final drive (each side)	0.2 gal. (0.9 L)
Hydraulic system	18.0 gal. (68.0 L)
Hydraulic tank	10.0 gal. (38.0 L)

All capacities are approximate values. Always refer to the machine's OM for exact refill levels. Check the dipstick, level eye, level plug, etc., to achieve the correct level.

Hydraulic Cylinders

Boom ¹ bore x rod diameter x stroke	3.3" x 1.9" x 24.9" (85 mm x 50 mm x 633 mm)
Arm ^{1,2} bore x rod diameter x stroke	3.1" x 2.2" x 28.6" (80 mm x 55 mm x 726 mm)
Bucket ¹ bore x rod diameter x stroke	2.8" x 1.8" x 23.6" (70 mm x 45 mm x 600 mm)
Swing – boom ¹ bore x rod diameter x stroke	3.7" x 2.4" x 17.7" (95 mm x 60 mm x 449 mm)
Blade ¹ (2) bore x rod diameter x stroke	4.3" x 2.4" x 7.8" (110 mm x 60 mm x 197 mm)

¹ Cushion on rod end

² Cushion on base end

The piston rods and cylinder bodies are made of high-strength steel. A shock-absorbing mechanism is fitted in all cylinders to ensure shock-free operation and extended piston life.

Dimensions

		Standard Arm & HVAC Cabin (US20/US40)	Long Arm & HVAC Cabin (US21/US41)	Standard Arm & Canopy (US30/US50)	Long Arm & Canopy (US31/US51)
Boom type		One-piece boom			
Arm type		Standard arm	Long arm	Standard arm	Long arm
Bucket type (SAE)		General-purpose			
Track type		Fixed (rubber)			
Shipping length	A	15' 8.2" (4780 mm)	15' 8.6" (4791 mm)	15' 8.2" (4780 mm)	15' 8.6" (4791 mm)
Overall height	B	8' 1.6" (2479 mm)			
Shipping width	C	5' 6.9" (1700 mm)			
Tail swing radius	D	2' 10.5" (875 mm)	3' 1.0" (940 mm)	2' 10.5" (875 mm)	3' 1.0" (940 mm)
Tail swing overhang (rear)*		-			
Tail swing overhang (side)	E	1.0" (25 mm)	3.7" (95 mm)	1.0" (25 mm)	3.7" (95 mm)
Counterweight clearance	F	1' 9.1" (537 mm)			
Upper structure width	H	4' 11.1" (1500 mm)			
Cabin height above house	I	3' 2.2" (971 mm)	3' 6.0" (1067 mm)	3' 2.2" (971 mm)	3' 6.0" (1067 mm)
Tumbler distance	J	5' 6.9" (1700 mm)			
Overall track length	K	6' 11.5" (2121 mm)			
Undercarriage width	L	5' 6.9" (1700 mm)			
Track gauge width	M	4' 7.1" (1400 mm)			
Track width	N	11.8" (300 mm)			
Track height	O	1' 6.7" (475.5 mm)			
Car body clearance	P	9.3" (235 mm)			
Blade height	Q	1' 3.0" (380 mm)			
Blade clearance	R	1' 4.1" (410 mm)			
Max. blade cut, below ground	S	1' 4.9" (429 mm)			

*Not shown on diagram
Less than zero indicated as "-"

US40/US41/US50/US51 packages include rotating piping as standard.

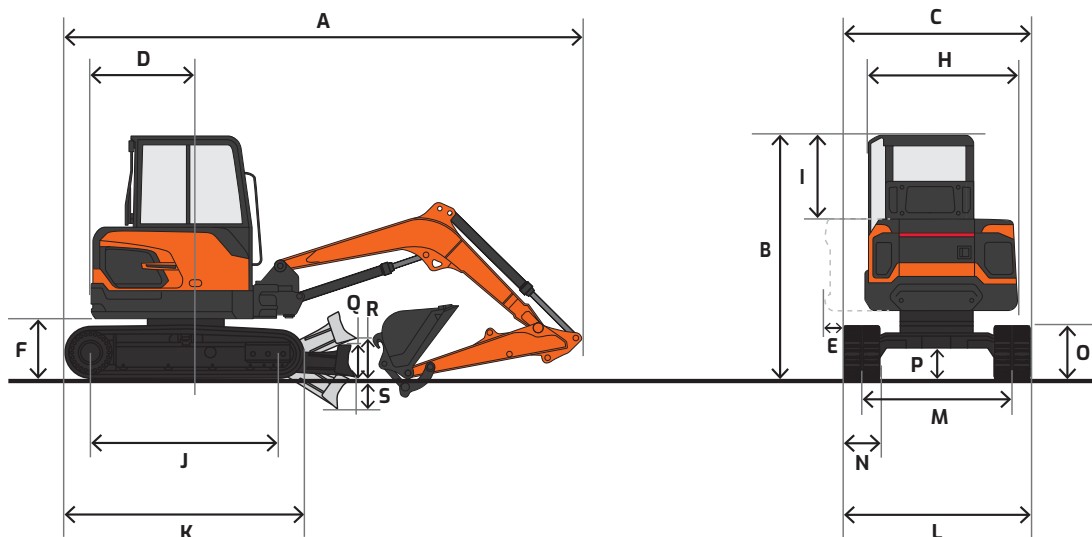

Working Range

		Standard Arm & HVAC Cabin (US20/US40)	Long Arm & HVAC Cabin (US21/US41)	Standard Arm & Canopy (US30/US50)	Long Arm & Canopy (US31/US51)
Boom length		8' 3.8" (2535 mm)			
Arm length		4' 4.4" (1330 mm)	4' 11.1" (1500 mm)	4' 4.4" (1330 mm)	4' 11.1" (1500 mm)
Bucket capacity (SAE)		3.9 ft. ³ (0.11 m ³)			
Max. digging reach	A	17' 6.8" (5355 mm)	18' 1.1" (5515 mm)	17' 6.8" (5355 mm)	18' 1.1" (5515 mm)
Max. digging reach (ground)	B	17' 2.1" (5235 mm)	17' 8.6" (5400 mm)	17' 2.1" (5235 mm)	17' 8.6" (5400 mm)
Max. digging depth	C	10' 8.9" (3275 mm)	11' 3.6" (3445 mm)	10' 8.9" (3275 mm)	11' 3.6" (3445 mm)
Max. dumping height	D	11' 8.9" (3580 mm)	12' 1.7" (3700 mm)	11' 8.9" (3580 mm)	12' 1.7" (3700 mm)
Max. digging height	E	16' 8.6" (5095 mm)	17' 1.3" (5215 mm)	16' 8.6" (5095 mm)	17' 1.3" (5215 mm)
Max. bucket pin height	F	14' 3.1" (4345 mm)	14' 7.6" (4460 mm)	14' 3.1" (4345 mm)	14' 7.6" (4460 mm)
Max. vertical wall depth	G	6' 6.0" (1980 mm)	6' 8.5" (2045 mm)	6' 6.0" (1980 mm)	6' 8.5" (2045 mm)
Max. vertical digging radius	H	13' 9.9" (4215 mm)	14' 3.3" (4350 mm)	13' 9.9" (4215 mm)	14' 3.3" (4350 mm)
Min. swing radius	I	6' 11.3" (2115 mm)	7' 0.5" (2145 mm)	6' 11.3" (2115 mm)	7' 0.5" (2145 mm)
Boom swing – left/right		66.5° / 53.5°			
Digging force, bucket		7143.0 lbf. (3240.0 kgf)			
Digging force, arm		4674.0 lbf. (2120.0 kgf)	4299 lbf. (1950 kgf)	4674 lbf. (2120 kgf)	4299 lbf. (1950 kgf)
Counterweight		1389 lb. (630 kg)	1609 lb. (730 kg)	1389 lb. (630 kg)	1609 lb. (730 kg)
Operating weight		8554 lb. (3880 kg)	8818 lb. (4000 kg)	8338 lb. (3782 kg)	8558 lb. (3882 kg)
Ground pressure		5.12 psi (0.36 kg/cm ²)			

US40/US41/US50/US51 packages include rotating piping as standard.

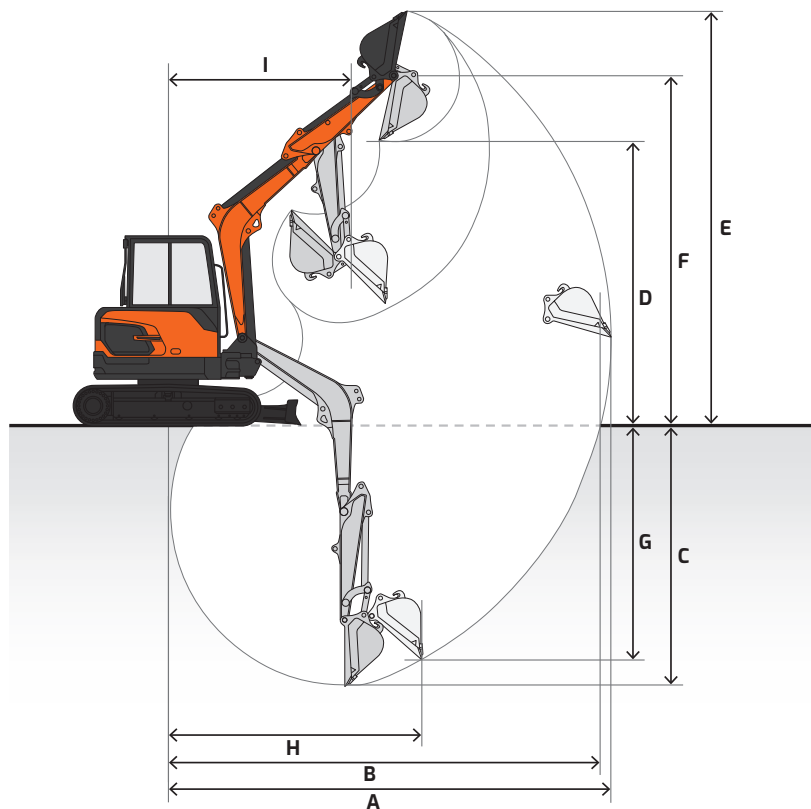

Bucket

	Standard Arm & HVAC Cabin (U520/U540)	Long Arm & HVAC Cabin (U521/U541)	Standard Arm & Canopy (U530/U550)	Long Arm & Canopy (U531/U551)
Boom	8' 3.8" (2535 mm)			
Arm	4' 4.4" (1330 mm)	4' 11.1" (1500 mm)	4' 4.4" (1330 mm)	4' 11.1" (1500 mm)
Shoe size	11.8" (300 mm)			
Track type	Fixed (rubber)			
Counterweight	1389 lb. (630 kg)	1609 lb. (730 kg)	1389 lb. (630 kg)	1609 lb. (730 kg)

Bucket Type	Model	Capacity* yd ³ (m ³)	Width in. (mm)	Weight lb. (kg)	Height in. (mm)	Length in. (mm)	Number of teeth	Connection/ Type
Quick-Hitch Ditching (QH03GB)	DC03GB-30QH	0.18 (0.14)	30 (762.0)	214 (97.0)	17.625 (447.6)	23.625 (600.0)	-	Quick-hitch
	DC03GB-36QH	0.22 (0.17)	36 (914.4)	250 (113.0)				
	DC03GB-42QH	0.26 (0.19)	42 (1066.8)	290 (131.0)				
Quick-Hitch Heavy-Duty (QH03QB)	HD03GB-12QH	0.06 (0.04)	12 (304.8)	125 (56.0)	18.375 (466.7)	30.875 (784.2)	3	Quick-hitch
	HD03GB-16QH	0.09 (0.07)	16 (406.4)	155 (70.0)			4	
	HD03GB-18QH	0.1 (0.07)	18 (457.2)	165 (75.0)			4	
	HD03GB-24QH	0.14 (0.10)	24 (609.6)	200 (91.0)			5	
Pin-On Ditching	DC03GB-30	0.18 (0.14)	31 (787.4)	235 (106.0)	23.0 (584.2)	26.75 (679.4)	-	Pin-on
	DC03GB-36	0.23 (0.17)	37 (939.8)	270 (122.0)				
	DC03GB-42	0.26 (0.20)	43 (1092.2)	300 (136.0)				
	DC03GB-48	0.31 (0.24)	49 (1244.6)	335 (152.0)				
Pin-On Heavy-Duty	HD03GB-12	0.06 (0.04)	13 (330.2)	125 (57.0)	22.625 (574.6)	32.0 (812.8)	3	Pin-on
	HD03GB-16	0.09 (0.07)	17 (431.8)	150 (68.0)			4	
	HD03GB-18	0.1 (0.07)	19 (482.6)	155 (70.0)			4	
	HD03GB-20	0.11 (0.08)	21 (533.4)	165 (75.0)			4	
	HD03GB-24	0.14 (0.10)	25 (635.0)	185 (84.0)			5	

*Capacity based on ISO 7451 and heaped with a 1:1 angle of repose

• Equipped with bolt-on wear shrouds

• Equipped with bolt-on teeth

• Equipped with bolt-on cutting edge

• These recommendations are given as a guide only and based on typical operating conditions.

Please consult with your DEVELON dealer to properly match buckets and attachments for the application.











US40/US41/US50/US51 packages include rotating piping as standard.

Lifting Capacity

 Rating over front  Rating over side or 360°











DX35Z-7 US20/US40 | Cabin & Standard Arm

Boom: 8' 3.8" (2535 mm) | Arm: 4' 4.4" (1330 mm) | Counterweight: 1389 lb. (630 kg) | Dozer Down | Bucket: None | Unit lb. (kg)

A (ft. or m) B (ft. or m)	5' (1.0 m)		10' (2.0 m)		15' (3.0 m)		20' (4.0 m)		Max. Reach		A
											
20' (4.0 m)					* 2000 * 910	* 2000 * 910			* 2100 * 950	* 2100 * 950	10.38' (3.16 m)
15' (3.0 m)					* 1870 * 850	* 1870 * 850	* 2000 * 910	* 2000 * 910	* 1760 * 800	* 1760 * 800	13.27' (4.05 m)
10' (2.0 m)					* 2470 * 1120	* 2470 * 1120	* 2080 * 940	* 2080 * 940	* 1690 * 770	* 1690 * 770	14.67' (4.47 m)
5' (1.0 m)					* 3300 * 1500	* 3300 * 1500	* 2360 * 1070	* 2360 * 1070	* 1760 * 800	* 1760 * 800	15.07' (4.59 m)
Ground Level			* 3350 * 1520	* 3350 * 1520	* 3740 * 1700	* 3740 * 1700	* 2530 * 1150	* 2530 * 1150	* 2010 * 910	* 2010 * 910	14.59' (4.45 m)
-5' (-1.0 m)	* 4650 * 2110	* 4650 * 2110	* 5990 * 2720	* 5990 * 2720	* 3570 * 1620	* 3570 * 1620			* 2260 * 1030	* 2260 * 1030	13.10' (3.99 m)
-10' (-2.0 m)			* 4090 * 1850	* 4090 * 1850	* 2330 * 1050	* 2330 * 1050			* 2180 * 990	* 2180 * 990	10.03' (3.06 m)

DX35Z-7 US20/US40 | Cabin & Standard Arm

Boom: 8' 3.8" (2535 mm) | Arm: 4' 4.4" (1330 mm) | Counterweight: 1389 lb. (630 kg) | Dozer Up | Bucket: None | Unit lb. (kg)

A (ft. or m) B (ft. or m)	5' (1.0 m)		10' (2.0 m)		15' (3.0 m)		20' (4.0 m)		Max. Reach		A
											
20' (4.0 m)					* 2000 * 910	1890 * 910			1970 890	1720 780	10.38' (3.16 m)
15' (3.0 m)					* 1870 * 850	* 1870 * 850	1340 610	1180 530	1310 600	1150 520	13.27' (4.05 m)
10' (2.0 m)					2080 940	1810 820	1320 600	1160 530	1100 500	970 440	14.67' (4.47 m)
5' (1.0 m)					1950 890	1690 770	1280 580	1120 510	1040 470	910 410	15.07' (4.59 m)
Ground Level			* 3350 * 1520	3010 1360	1890 860	1620 740	1250 570	1090 490	1080 490	940 430	14.59' (4.45 m)
-5' (-1.0 m)	* 4650 * 2110	* 4650 * 2110	3680 1670	3050 1380	1880 850	1620 740			1260 570	1100 500	13.10' (3.99 m)
-10' (-2.0 m)			3790 1720	3150 1430	1960 890	1690 770			1910 870	1650 750	10.03' (3.06 m)

A Distance from center of rotation
B Height

NOTE: Lifting capacities are in compliance with SAE 1097 and ISO 10567. Machine in lifting mode with power boost turned on. Load point is the end of the arm. Rated loads shown do not exceed 75% of minimum tipping loads or 87% of hydraulic capacities. Rated loads marked with an asterisk (*) are limited by hydraulic capacities. The least stable position is over the side. The total mass of machine includes the mass of the boom, arm, counterweight, all operating fluids and 165 lb. (75 kg) operator.

US40/US41/US50/US51 packages include rotating piping as standard.

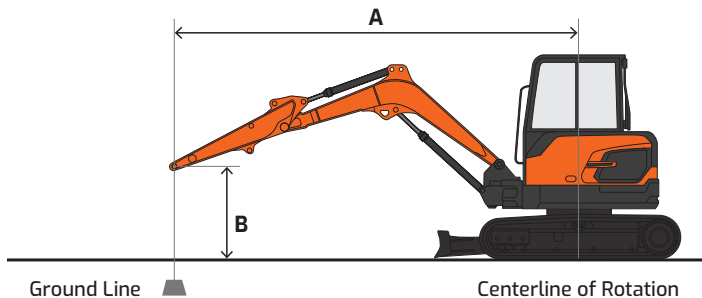











Lifting Capacity

 Rating over front  Rating over side or 360°











DX35Z-7 US21/US41 | Cabin & Long Arm

Boom: 8' 3.8" (2535 mm) | Arm: 4' 4.11" (1500 mm) | Counterweight: 1609 lb. (730 kg) | Dozer Down | Bucket: None | Unit lb. (kg)

A (ft. or m) B (ft. or m)	5' (1.0 m)		10' (2.0 m)		15' (3.0 m)		20' (4.0 m)		Max. Reach		A
											
20' (4.0 m)					* 1740 * 790	* 1740 * 790			* 1800 * 820	* 1800 * 820	11.22' (3.42 m)
15' (3.0 m)					* 1690 * 770	* 1690 * 770	* 1830 * 830	* 1830 * 830	* 1530 * 690	* 1530 * 690	13.91' (4.24 m)
10' (2.0 m)			* 3270 * 1480	* 3270 * 1480	* 2290 * 1040	* 2290 * 1040	* 1980 * 900	* 1980 * 900	* 1480 * 670	* 1480 * 670	15.22' (4.64 m)
5' (1.0 m)					* 3170 * 1440	* 3170 * 1440	* 2290 * 1040	* 2290 * 1040	* 1540 * 700	* 1540 * 700	15.60' (4.76 m)
Ground Level			* 3460 * 1570	* 3460 * 1570	* 3700 * 1680	* 3700 * 1680	* 2510 * 1140	* 2510 * 1140	* 1740 * 790	* 1740 * 790	15.15' (4.62 m)
-5' (-1.0 m)	* 4180 * 1890	* 4180 * 1890	* 6280 * 2850	* 6280 * 2850	* 3640 * 1650	* 3640 * 1650	* 2390 * 1080	* 2390 * 1080	* 2170 * 980	* 2170 * 980	13.74' (4.19 m)
-10' (-2.0 m)			* 4600 * 2080	* 4600 * 2080	* 2710 * 1230	* 2710 * 1230			* 2160 * 980	* 2160 * 980	10.92' (3.33 m)

DX35Z-7 US21/US41 | Cabin & Long Arm

Boom: 8' 3.8" (2535 mm) | Arm: 4' 4.11" (1500 mm) | Counterweight: 1609 lb. (730 kg) | Dozer Up | Bucket: None | Unit lb. (kg)

A (ft. or m) B (ft. or m)	5' (1.0 m)		10' (2.0 m)		15' (3.0 m)		20' (4.0 m)		Max. Reach		A
											
20' (4.0 m)					* 1740 * 790	* 1740 * 790			* 1800 * 820	1620 740	11.22' (3.42 m)
15' (3.0 m)					* 1690 * 770	* 1690 * 770	1440 650	1270 580	1300 590	1150 520	13.91' (4.24 m)
10' (2.0 m)			* 3270 * 1480	* 3270 * 1480	2220 1010	1930 880	1410 640	1240 560	1110 500	980 440	15.22' (4.64 m)
5' (1.0 m)					2090 950	1810 820	1360 620	1200 540	1050 480	920 420	15.60' (4.76 m)
Ground Level			* 3460 * 1570	3190 1450	2010 910	1730 790	1330 600	1160 530	1090 490	950 430	15.15' (4.62 m)
-5' (-1.0 m)	* 4180 * 1890	* 4180 * 1890	3880 1760	3220 1460	2000 910	1720 780	1330 600	1160 530	1250 570	1090 500	13.74' (4.19 m)
-10' (-2.0 m)			3980 1810	3310 1500	2050 930	1770 800			1780 810	1540 700	10.92' (3.33 m)

A Distance from center of rotation
B Height

NOTE: Lifting capacities are in compliance with SAE 1097 and ISO 10567. Machine in lifting mode with power boost turned on. Load point is the end of the arm. Rated loads shown do not exceed 75% of minimum tipping loads or 87% of hydraulic capacities. Rated loads marked with an asterisk (*) are limited by hydraulic capacities. The least stable position is over the side. The total mass of machine includes the mass of the boom, arm, counterweight, all operating fluids and 165 lb. (75 kg) operator.

US40/US41/US50/US51 packages include rotating piping as standard.

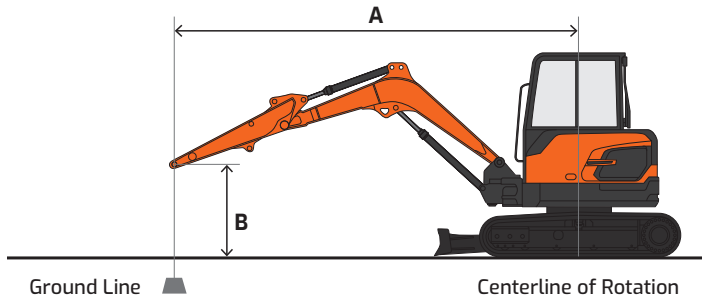











Lifting Capacity

 Rating over front  Rating over side or 360°











DX35Z-7 US30/US50 | Canopy & Standard Arm

Boom: 8' 3.8" (2535 mm) | Arm: 4' 4.4" (1330 mm) | Counterweight: 1389 lb. (630 kg) | Dozer Down | Bucket: None | Unit lb. (kg)

A (ft. or m) B (ft. or m)	5' (1.0 m)		10' (2.0 m)		15' (3.0 m)		20' (4.0 m)		Max. Reach		A
											
20' (4.0 m)					* 2000 * 910	* 2000 * 910			* 2010 * 950	* 2010 * 950	10.38' (3.16 m)
15' (3.0 m)					* 1870 * 850	* 1870 * 850	* 2000 * 910	* 2000 * 910	* 1760 * 800	* 1760 * 800	13.27' (4.05 m)
10' (2.0 m)					* 2470 * 1120	* 2470 * 1120	* 2080 * 940	* 2080 * 940	* 1690 * 770	* 1690 * 770	14.67' (4.47 m)
5' (1.0 m)					* 3300 * 1500	* 3300 * 1500	* 2360 * 1070	* 2360 * 1070	* 1760 * 800	* 1760 * 800	15.07' (4.59 m)
Ground Level			* 3350 * 1520	* 3350 * 1520	* 3740 * 1700	* 3740 * 1700	* 2530 * 1150	* 2530 * 1150	* 2010 * 910	* 2010 * 910	14.59' (4.45 m)
-5' (-1.0 m)	* 4650 * 2110	* 4650 * 2110	* 5990 * 2720	* 5990 * 2720	* 3570 * 1620	* 3570 * 1620			* 2260 * 1030	* 2260 * 1030	13.10' (3.99 m)
-10' (-2.0 m)			* 4090 * 1850	* 4090 * 1850	* 2330 * 1050	* 2330 * 1050			* 2180 * 990	* 2180 * 990	10.03' (3.06 m)

DX35Z-7 US30/US50 | Canopy & Standard Arm

Boom: 8' 3.8" (2535 mm) | Arm: 4' 4.4" (1330 mm) | Counterweight: 1389 lb. (630 kg) | Dozer Up | Bucket: None | Unit lb. (kg)

A (ft. or m) B (ft. or m)	5' (1.0 m)		10' (2.0 m)		15' (3.0 m)		20' (4.0 m)		Max. Reach		A
											
20' (4.0 m)					* 2000 * 910	1830 830			1910 860	1670 760	10.38' (3.16 m)
15' (3.0 m)					* 1870 * 850	1840 830	1290 590	1140 520	1270 570	1110 510	13.27' (4.05 m)
10' (2.0 m)					2010 910	1750 790	1280 580	1120 510	1060 480	930 420	14.67' (4.47 m)
5' (1.0 m)					1890 860	1630 740	1230 560	1080 490	1000 450	880 400	15.07' (4.59 m)
Ground Level			* 3350 * 1520	2910 1320	1820 820	1570 710	1200 540	1050 480	1040 470	910 410	14.59' (4.45 m)
-5' (-1.0 m)	* 4650 * 2110	* 4650 * 2110	3550 1610	2950 1340	1820 820	1570 710			1210 550	1060 480	13.10' (3.99 m)
-10' (-2.0 m)			3670 1660	3050 1380	1890 860	1640 740			1850 840	1600 730	10.03' (3.06 m)

A Distance from center of rotation
B Height

NOTE: Lifting capacities are in compliance with SAE 1097 and ISO 10567. Machine in lifting mode with power boost turned on. Load point is the end of the arm. Rated loads shown do not exceed 75% of minimum tipping loads or 87% of hydraulic capacities. Rated loads marked with an asterisk (*) are limited by hydraulic capacities. The least stable position is over the side. The total mass of machine includes the mass of the boom, arm, counterweight, all operating fluids and 165 lb. (75 kg) operator.

US40/US41/US50/US51 packages include rotating piping as standard.

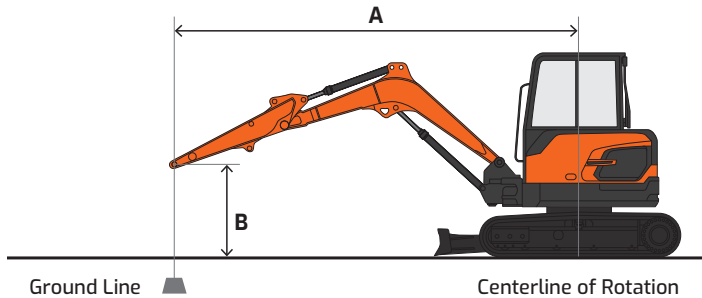











Lifting Capacity

 Rating over front  Rating over side or 360°











DX35Z-7 US31/US51 | Canopy & Long Arm

Boom: 8' 3.8" (2535 mm) | Arm: 4' 4.11" (1500 mm) | Counterweight: 1609 lb. (730 kg) | Dozer Down | Bucket: None | Unit lb. (kg)

A (ft. or m) B (ft. or m)	5' (1.0 m)		10' (2.0 m)		15' (3.0 m)		20' (4.0 m)		Max. Reach		A
											
20' (4.0 m)									* 1790 * 810	* 1790 * 810	11.24' (3.43 m)
15' (3.0 m)							* 1750 * 800	1490 680	* 1530 * 690	1350 610	13.90' (4.24 m)
10' (2.0 m)					* 2170 * 980	* 2170 * 980	* 1900 * 860	1460 660	* 1470 * 670	1150 520	15.22' (4.64 m)
5' (1.0 m)					* 3060 * 1390	2160 980	* 2220 * 1010	1410 640	* 1530 * 700	1090 490	15.60' (4.76 m)
Ground Level			* 3470 * 1570	* 3470 * 1570	* 3630 * 1650	2070 940	* 2470 * 1120	1370 620	* 1730 * 790	1120 510	15.14' (4.62 m)
-5' (-1.0 m)	* 4180 * 1900	* 4180 * 1900	* 6280 * 2850	4000 1820	* 3620 * 1640	2060 930	* 2390 * 1080	1370 620	* 2170 * 990	1290 590	13.74' (4.19 m)
-10' (-2.0 m)	* 6920 * 3140	* 6290 * 3140	* 4770 * 2170	4110 1860	* 2790 * 1270	2120 960			* 2230 * 1010	1840 830	10.89' (3.32 m)

DX35Z-7 US31/US51 | Canopy & Long Arm

Boom: 8' 3.8" (2535 mm) | Arm: 4' 4.11" (1500 mm) | Counterweight: 1609 lb. (730 kg) | Dozer Up | Bucket: None | Unit lb. (kg)

A (ft. or m) B (ft. or m)	5' (1.0 m)		10' (2.0 m)		15' (3.0 m)		20' (4.0 m)		Max. Reach		A
											
20' (4.0 m)									1780 810	1560 710	11.24' (3.43 m)
15' (3.0 m)							1380 630	1220 550	1250 570	1100 500	13.90' (4.24 m)
10' (2.0 m)					2150 970	1870 850	1360 610	1190 540	1060 480	930 420	15.22' (4.64 m)
5' (1.0 m)					2000 910	1730 780	1300 590	1140 520	1000 450	870 400	15.60' (4.76 m)
Ground Level			* 3470 * 1570	3030 1380	1910 870	1640 750	1260 570	1100 500	1030 470	900 410	15.14' (4.62 m)
-5' (-1.0 m)	* 4180 * 1900	* 4180 * 1900	3710 1680	3060 1390	1900 860	1630 740	1260 570	1100 500	1190 540	1040 470	13.74' (4.19 m)
-10' (-2.0 m)	* 6920 * 3140	* 6290 * 3140	3810 1730	3160 1430	1960 890	1690 770			1700 770	1480 670	10.89' (3.32 m)

A Distance from center of rotation
B Height

NOTE: Lifting capacities are in compliance with SAE 1097 and ISO 10567. Machine in lifting mode with power boost turned on. Load point is the end of the arm. Rated loads shown do not exceed 75% of minimum tipping loads or 87% of hydraulic capacities. Rated loads marked with an asterisk (*) are limited by hydraulic capacities. The least stable position is over the side. The total mass of machine includes the mass of the boom, arm, counterweight, all operating fluids and 165 lb. (75 kg) operator.

US40/US41/US50/US51 packages include rotating piping as standard.

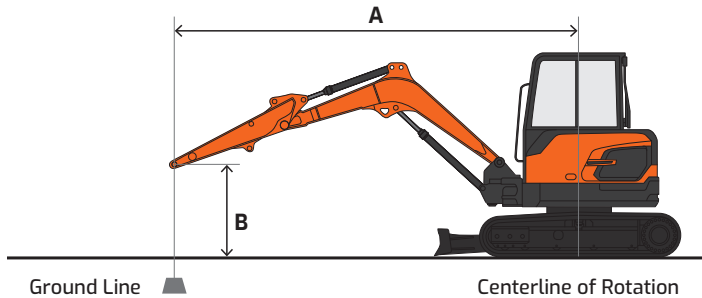

Standard & Optional Equipment

| Standard Base Package, US20

■ Standard ● Optional

Engine

Emissions (EPA), T4f	■
Direct fuel injected	■
Fuel filter with water separator	■
Coolant recovery tank	■
Dual element dry-type air filter	■
Electronic engine control (ECU)	■
Auto preheat cold start assist	■
Auto idle	■
Overheat & low oil pressure engine protection	■

Hydraulic

Variable axial piston main pump	■
Pilot-operated control valves	■
Pilot gear pump (tandem)	■
Axial piston swing motor	■
Spring-applied hydraulic release brake	■
Axial piston travel motor (high/low, auto)	■
Auxiliary hydraulics, two-way	■
Adjustable auxiliary flow	■

Electrical

Alternator – 13.5 V, 75 A	■
12 V battery, 400 CCA @ 0° F (-18° C)	■
Lights: cabin (1), boom (1)	■
Additional lighting	●
Rotating beacon	●
Hour meter	■
Engine restart prevention system	■
Laptop service port	■
Self-diagnostics system	■

Cabin

Steel, all-weather & sound suppressed	■
ROPS/TOPS	■
Front window with wiper/washer	■
Tinted safety glass	■
Pull-up type front window	■
Lockable doors	■
Seat	■
- 2" (51 mm) seat belt	■
- Adjustable height & recline	■
Adjustable armrests	■
Air conditioner with heater	■
Mirrors	■
AM/FM stereo & Bluetooth®	■
Speakers (2)	■
Power socket, 12 V	■
Interior light	■
Storage for operator's manuals	■

Controls

Joystick controls	■
- Two hydraulic joysticks control boom, arm, bucket & slew functions	■
- Thumbwheels control auxiliary hydraulics (if equipped)	■
Blade control lever	■
Pattern control change valve (SAE, ISO)	■
Engine speed control dial	■
Travel pedals with hand levers	■
Switches, console-mounted	■
- Starter switch (key)	■
- Heater/AC control panel	■
- Rotating beacon (if equipped)	■
- 12 V power socket & USB charger	■
- Keypad buttons	■
- Overload warning	■
- Travel/swing alarm	■
- Light	■
- Work lights	■
- Wiper & washer	■
- Auto idle	■
Emergency stop switch	■

Display Monitor & Warnings

Buzzer	■
- Engine oil pressure	■
- Coolant temperature	■
Touch screen display monitor	■
- Digital clock	■
- Menu select button	■
- Back button	■
- Fuel gauge	■
- Engine coolant temperature	■
- Hydraulic oil temperature	■
- Mode	■
- Tachometer	■
- Operating mode/flow setting selector	■
Indicator lights	■
- Air filter restriction indicator	■
- Engine check warning light	■
- Hydraulic oil warning	■
- Fuel warning	■
- Auto idle indicator	■
- Auxiliary flow mode indicator	■
- Engine oil pressure light with audible alarm	■
- Preheat (cold start assist) indicator	■
- Two-speed travel indicator light	■
Travel alarm	●

Undercarriage

Track rollers, upper	1
Track rollers, lower	4
Rubber tracks – 300 mm	■

Other

Centralized lubrication	■
- Swing pinion	■
- Swing bearing	■
Dozer blade	■
Manuals	■
- Operation	■
- AEM Safety Manual	■
Vandalism protection	■
- Lockable panels	■
- Lockable fluid fill points	■
MY DEVELON (telematics)	■

Certain specification(s) are based on engineering calculations and are not actual measurements. Specification(s) are provided for comparison purposes only and are subject to change without notice. Specification(s) for your individual DEVELON equipment will vary based on normal variations in design, manufacturing, operating conditions, and other factors. Pictures of DEVELON units may show other than standard equipment.

Powered by Innovation

DEVELON

A brand of HD Hyundai Infracore.

na.develon-ce.com/dx35z-7

DX35Z-7 Crawler Excavator Spec Sheet
Printed in the U.S.A.
23906_002_D082224

©2024 HD Hyundai Infracore. All rights reserved.